



GANESH INSTITUTE OF ENGINEERING AND TECHNOLOGY (GIET),  
Jagannath Prasad, Andharua, BHUBANESWAR

# Energy Conversion-1 (Th- 01)

(As per the 2019-20 syllabus of the SCTE&VT,  
Bhubaneswar, Odisha)



Fourth Semester

Electrical Engg.

**Prepared By:** Er.SATYABRAT DAS

## CONTENT

| <b>Sl. No.</b> | <b>Name of the Chapter</b> | <b>Expected Marks</b> |
|----------------|----------------------------|-----------------------|
| 01             | D.C. Generator             | 30                    |
| 02             | D.C. Motor                 | 25                    |
| 03             | Single Phase Transformer   | 25                    |
| 04             | Auto Transformer           | 10                    |
| 05             | Instrument Transformer     | 10                    |

## Chapter No-01

### D.C.GENERATOR

**1.1-Definition:** It is defined as a d.c Electric Machine which converts Mechanical Energy in to Electrical Energy. This energy conversion takes place in the armature only.

#### **Block Diagram:**

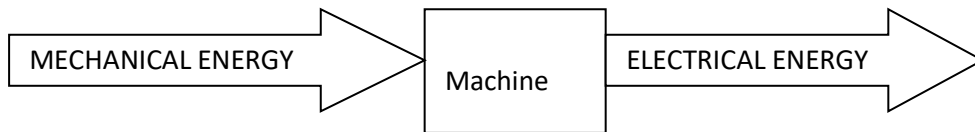

#### **Principle:**

It works under the principle of dynamically induced e.m.f.(i.e. whenever a conductor moves under the influence of uniform magnetic field ,then according to faradays laws of electromagnetic induction , certain emf will be induced in the conductors. )

#### **1.2- Construction:**

A D.C. generator has following important parts

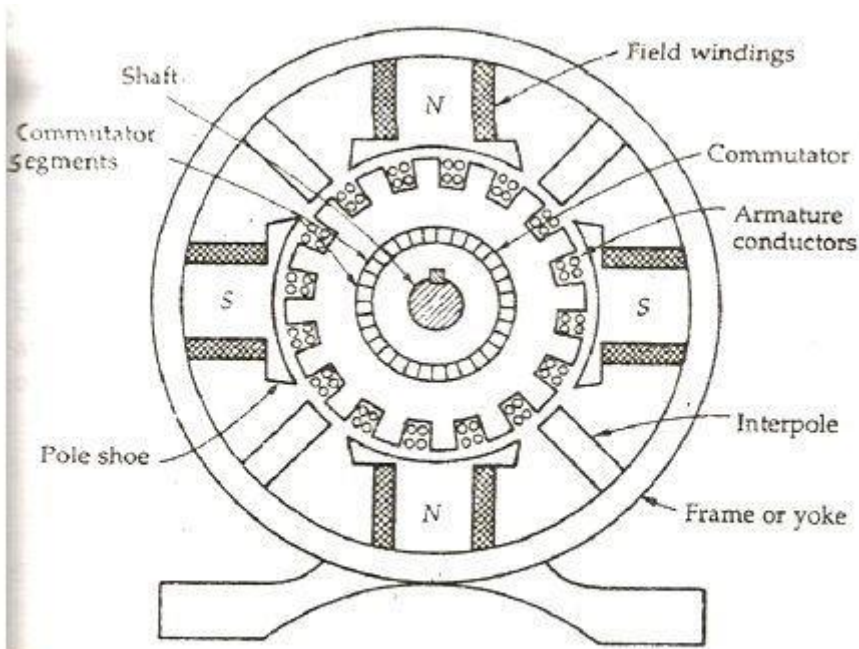

### 1.2.1. Eye Bolt

This is a provision made on the yoke of a machine to lift or shift the machine from one place to another place easily. This is also called as magnetic frame.

### 1.2.2. Yoke

This is an outer covering of the machine which protects to all of its internal parts from entry of exteriors. This is a cylindrical drum like structure and made with silicon steel or cast steel. This is also called as magnetic frame.

### 1.2.3. Magnetic Poles:

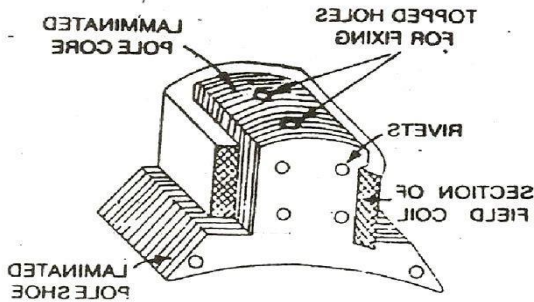

This is made up of cast iron or silicon steel having high permeability. Its core is always laminated in order to reduce eddy current loss. Its face or pole shoe is made curved in order to get uniform flux distribution. It is always fixed with the yoke of the machine.

### 1.2.4. Pole winding or Field Windings:

Several turns of copper wire with required gauge are wound over the pole body and are called as field windings. Flux is produced from the magnetic pole when this winding is excited by a d.c. source.

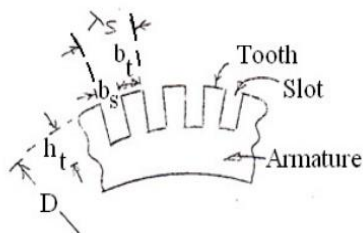

### 1.2.5. Armature:

This is the rotating part of the machine. It is a cylindrical drum like structure made up of ferromagnetic material having high permeability. Its surface has a number of slots & teeth. The grooves or holes are called as Slots but projected portions are called as teeth.

### 1.2.6. Armature windings:

Several turns of copper wires are embedded through the slots of the armature & are called as armature winding. These windings are of Lap & Wave connected.

### 1.2.7. Commutator:

This is of course a rotating part of the machine mounted on the shaft and rotates in the same speed of the armature. The commutator is also called as Split Ring. This is made up of V shaped hard drawn copper lug. It has as many Segments as the number of armature coils. The main function of this commutator is to convert a.c. to d.c.

### 1.2.8. Brush:

This is a fixed part & kept in a holder called as brush holder. It is always pressed against the commutator surface. It is generally made up of Carbon which is a hardest material. The main function of this carbon is to collect direct current from the commutator surface. It also polishes the commutator surface.

### **Working:**

Using any prime mover, the armature of d.c. generator is rotated at its rated speed. At the same time, flux from the magnetic poles comes & links with the rotating armature conductors. According to the Faradays Electro Magnetic Induction, certain emf is induced in the armature conductors. This emf is alternating in nature but converted in to d.c. by means of commutator. This d.c. is being collected by the brushes & send to the external circuit for use.

### **1.3-Types of D.C. Generators**

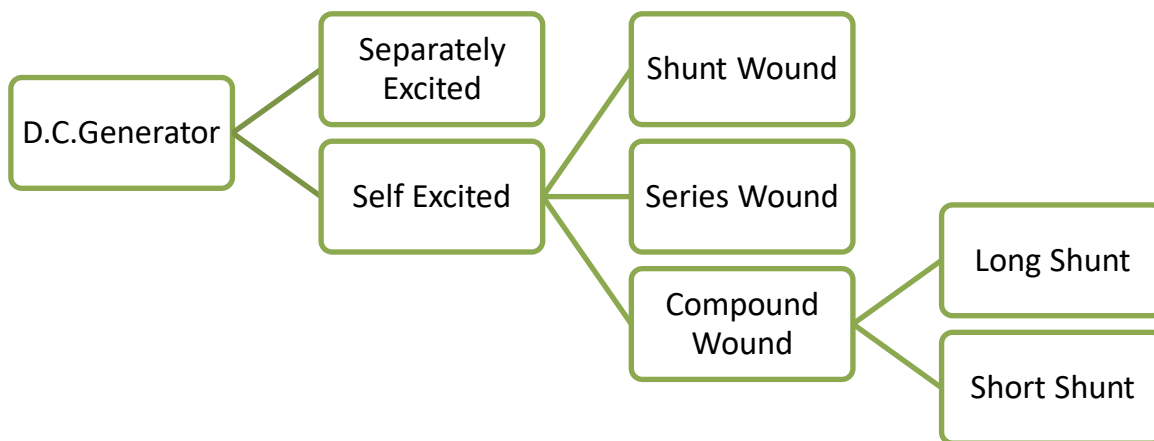

### **1.3.1-Separately Excited D.C. Generator:**

Definition: It is defined as a D.C. Generator in which it's field windings are excited or energised by the help of external d.c. source.

## Symbol & Circuit Diagram:

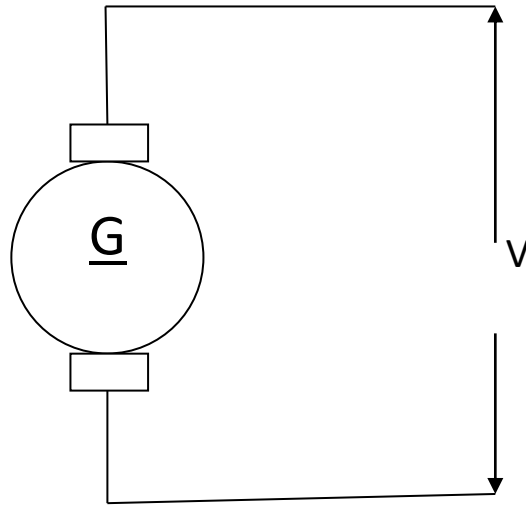

## Voltage Equation:

Let,  $E_g$  = Generated emf , V

$V$  = Terminal or Supplied or Load Voltage, V

$V_b$  = Brush contact drop or voltage drop in each brush, V

$I_a$  = Armature Current , A

$R_a$  = Armature winding Resistance or Armature Resistance,  $\Omega$

Applying KVL to the above closed circuit we get,

$$E_g = V + I_a R_a + 2 V_b \quad \text{V}$$

### **1.3.2-Self Excited D.C. Generator:**

Definition: It is defined as a D.C. Generator in which it's field windings are excited or energised by the help of current produced of it's own. It is of following three types

#### **a)D.C. Shunt Generator**

Definition: If field windings of a self excited d.c. generator are connected in parallel with the Armature windings or circuits then that type of generator is known as d.c. shunt generator.

## Symbol & Circuit Diagram:

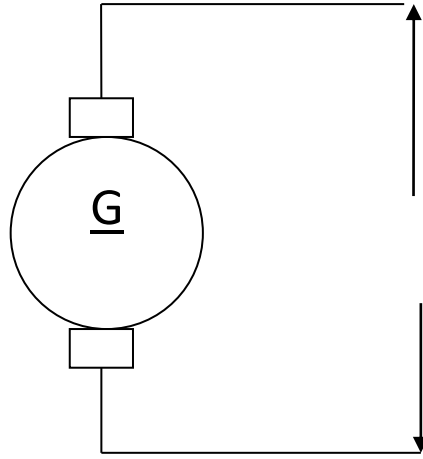

Let,  $E_g$  = Generated emf , V

$V$  = Terminal or Supplied or Load Voltage, V

$V_b$  = Brush contact drop or voltage drop in each brush, V

$I_a$  = Armature Current, A

$I_{sh}$  = Shunt field current, A

$I_L$  = Line or Load Current, A

$R_a$  = Armature winding Resistance or Armature Resistance,  $\Omega$

$R_{sh}$  = Shunt field winding Resistance or Shunt Resistance,  $\Omega$

### **Current Relation:**

In the above figure, applying KCL at the node "B" we get

$$I_a = I_L + I_{sh} \quad \mathbf{A}$$

### Voltage Equations or Voltage Relations :

Applying KVL to the mesh relating to Load & Armature, we get

$$E_g = V + I_a R_a + 2 V_b \quad \mathbf{V}$$

Applying KVL to the mesh relating to Load & Field, we get

$$V = I_{sh} R_{sh} \quad \mathbf{V}$$

Applying KVL to the mesh relating to Armature & Field, we get

$$E_g + I_a R_a = I_{sh} R_{sh} \quad \mathbf{V}$$

### **b) D.C. Series Generator**

Definition: If field windings of a self excited d.c. generator are connected in series with the Armature windings or circuits then that type of generator is known as d.c. series generator.

## Symbol & Circuit Diagram:

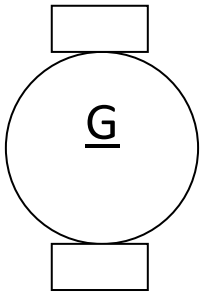

Let,  $E_g$  = Generated emf , V

$V$  = Terminal or Supplied or Load Voltage, V

$V_b$  = Brush contact drop or voltage drop in each brush, V

$I_a$  = Armature Current, A

$I_{se}$  = Series field current, A

$I_L$  = Line or Load Current, A

$R_a$  = Armature winding Resistance or Armature Resistance,  $\Omega$

$R_{se}$  = Series field winding Resistance or Series Resistance,  $\Omega$

### **Current Relation:**

In the above figure,  $I_a = I_{se} = I_L$  A

### Voltage Equation or Voltage Relation :

Applying KVL to the mesh relating to Load & Armature, we get

$$E_g = V + I_a (R_a + R_{se}) + 2 V_b \quad \text{V}$$

### **c) D.C. Compound Generator**

Definition: If field windings of a self excited d.c. generator are connected partially in series & parallel with the Armature windings or circuits then that type of generator is known as d.c. Compound generator. It is again of two types based on how the shunt field is connected with the armature.

#### **i) Long Shunt Compound Generator :**

Definition: In a compound generator, if the shunt field windings are connected across the armature & series field windings then it is called as **Long Shunt Compound Generator**.

## Symbol & Circuit Diagram:

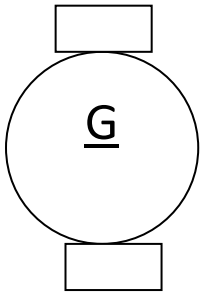

Let,  $E_g$  = Generated emf , V

$V$  = Terminal or Supplied or Load Voltage, V

$V_b$  = Brush contact drop or voltage drop in each brush, V

$I_a$  = Armature Current, A

$I_{se}$  = Series field current, A

$I_{sh}$  = Shunt field current, A

$I_L$  = Line or Load Current, A

$R_a$  = Armature winding Resistance or Armature Resistance,  $\Omega$

$R_{se}$  = Series field winding Resistance or Series Resistance,  $\Omega$

$R_{sh}$  = Shunt field winding Resistance or Shunt Resistance,  $\Omega$

### **Current Relations:**

In the above figure, applying KCL at the node "B" we get

$$I_a = I_L + I_{sh} \quad \text{A}$$

Again

$$I_a = I_{se} \quad \text{A}$$

### Voltage Equations or Voltage Relations :

Applying KVL to the mesh relating to Load & Armature, we get

$$E_g = V + I_a (R_a + R_{se}) + 2 V_b \quad \text{V}$$

Applying KVL to the mesh relating to Load & Field, we get

$$V = I_{sh} R_{sh} \quad \text{V}$$

Applying KVL to the mesh relating to Armature & Field, we get

$$E_g + I_a (R_a + R_{se}) = I_{sh} R_{sh} \quad \text{V}$$

## ii) Short Shunt Compound Generator :

Definition: In a compound generator, if the shunt field windings are connected across the armature only leaving the series field windings then it is called as Short **Shunt Compound Generator**.

Symbol & Circuit Diagram:

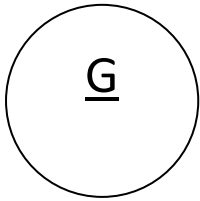

Let,  $E_g$  = Generated emf , V

$V$  = Terminal or Supplied or Load Voltage, V

$V_b$  = Brush contact drop or voltage drop in each brush, V

$I_a$  = Armature Current, A

$I_{se}$  = Series field current, A

$I_{sh}$  = Shunt field current, A

$I_L$  = Line or Load Current, A

$R_a$  = Armature winding Resistance or Armature Resistance,  $\Omega$

$R_{se}$  = Series field winding Resistance or Series Resistance,  $\Omega$

$R_{sh}$  = Shunt field winding Resistance or Shunt Resistance,  $\Omega$

### Current Relations:

In the above figure, applying KCL at the node "B" we get

$$I_a = I_L + I_{sh}$$

A

But

$$I_{se} = I_a = I_L$$

A

### Voltage Equations or Voltage Relations :

Applying KVL to the mesh relating to Load & Armature, we get

$$E_g = V + I_L R_{se} + I_a R_a + 2 V_b$$

V

Applying KVL to the mesh relating to Load, Series field & Shunt field, we get

$$I_{sh} R_{sh} = V + I_L R_{se}$$

V

Applying KVL to the mesh relating to Armature & Shunt field, we get

$$E_g = I_{sh} R_{sh} + I_a R_a + 2 V_b$$

V

## CHAPTER-2

### DC MOTOR

#### 2.1 Principle of DC motor

##### DEFINATION

It is defined as a DC electric machine which converts electrical energy in to mechanical energy.

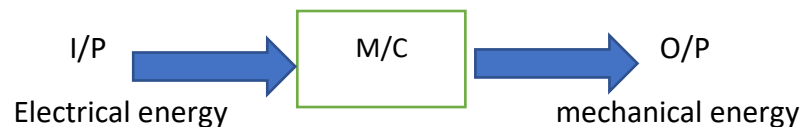

##### Principle:

- It works under the principle that whenever a current carrying conductor is placed in a magnetic field then a mechanical force is experienced by the conductor.

##### Construction of dc motor:

The construction of dc motor is same as that of dc generator. So the same machine can be used as motor and generator.

##### Working:

When DC supply is given to the armature conductor through carbon brushes and commutator then direct current starts to flow through the armature windings at the same time magnetic flux from north poles. Now the current carrying armature conductors are in the uniform magnetic field. So a mechanical force is experienced by the armature conductor. Since two ends of the armature shaft are mounted by ball bearing. So the armature will start rotating in one direction. The direction of rotation can be determined by Fleming's left hand rule.

#### 2.2 significance of back emf , symbol , ckt diagram and voltage equation

##### Back emf ( $E_b$ ) /counter emf

- It is defined as an induced e.m.f , which opposes the applied voltage.
- The formula for back emf is given by

$$E_b = \frac{\phi z N}{60} \times \frac{P}{A} , V$$

$$E_b \propto \phi N \quad [\text{Since } Z.P.A \text{ are constant}]$$

Significance of back emf

The back emf work as a regulator for the motor that means it automatically changes the armature current according to the load.

**Symbol and circuit diagram:**

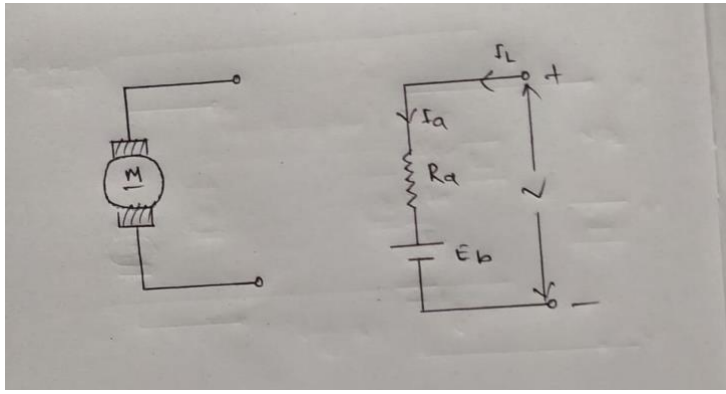

Let

$E_b$ = back emf / counter emf , v

$V$ = applied voltage, V

$V_b$ = Brush contact drop ,V

$I_L$ = line current , A

$I_a$ = armature current ,A

$R_a$ = armature winding resistance ,  $\Omega$

Applying KVL to the above closed circuit we get

$$-I_a R_a - E_b + V - 2 V_b = 0$$

$$\Rightarrow E_b = V - I_a R_a - 2 V_b$$

$$I_a = I_L$$

This is called voltage equation of a DC motor

**2.3 voltage equation of motor and condition for maximum power developed.**

**Condition for maximum power developed by the motor**

We know that in a dc motor

$$E_b = V - I_a R_a - 2V_b$$

Now we neglecting the brush contact drop so

$$E_b = V - I_a R_a \text{ -----(i)}$$

If we multiply  $I_a$  in both sides of equation I we get

$$E_b I_a = V I_a - I_a^2 R_a$$

$$P_M = V I_a - I_a^2 R_a \quad \text{----- (ii) [ } E_b I_a = P_m \text{]}$$

For maximum power

$$\frac{d(P_m)}{d I_a}$$

Differentiating power w r t  $I_a$

$$\begin{aligned} \Rightarrow \frac{d(V I_a - I_a^2 R_a)}{d I_a} &= 0 \\ \Rightarrow \frac{d(V I_a)}{d I_a} - \frac{d(I_a^2 R_a)}{d I_a} &= 0 \\ \Rightarrow V - 2 I_a R_a &= 0 \\ \Rightarrow V &= 2 I_a R_a \\ \Rightarrow I_a R_a &= V/2 \end{aligned}$$

Now we putting value of  $I_a R_a$  in equation( I )

We get

$$E_b = V - \frac{V}{2}$$

$$\Rightarrow E_b = \frac{2V - V}{2}$$

$$\Rightarrow E_b = \frac{V}{2}$$

When the back emf is half of the supply voltage the motor gives maximum power. This is the condition for maximum power developed of the DC motor

## 2.6 Types of DC motor

### Classification of DC motor

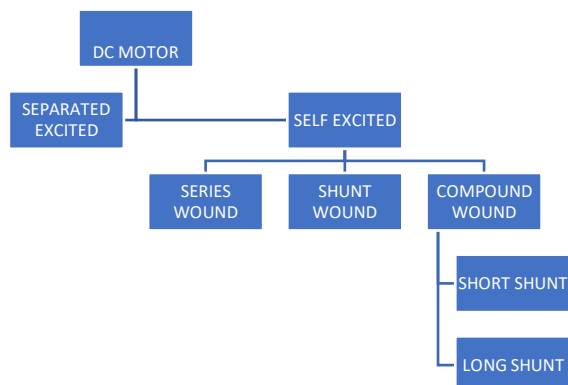

## Separated Excited DC motor

- ⇒ If the field winding of a DC motor are excited by some external DC source then it is called as separately excited DC motor.

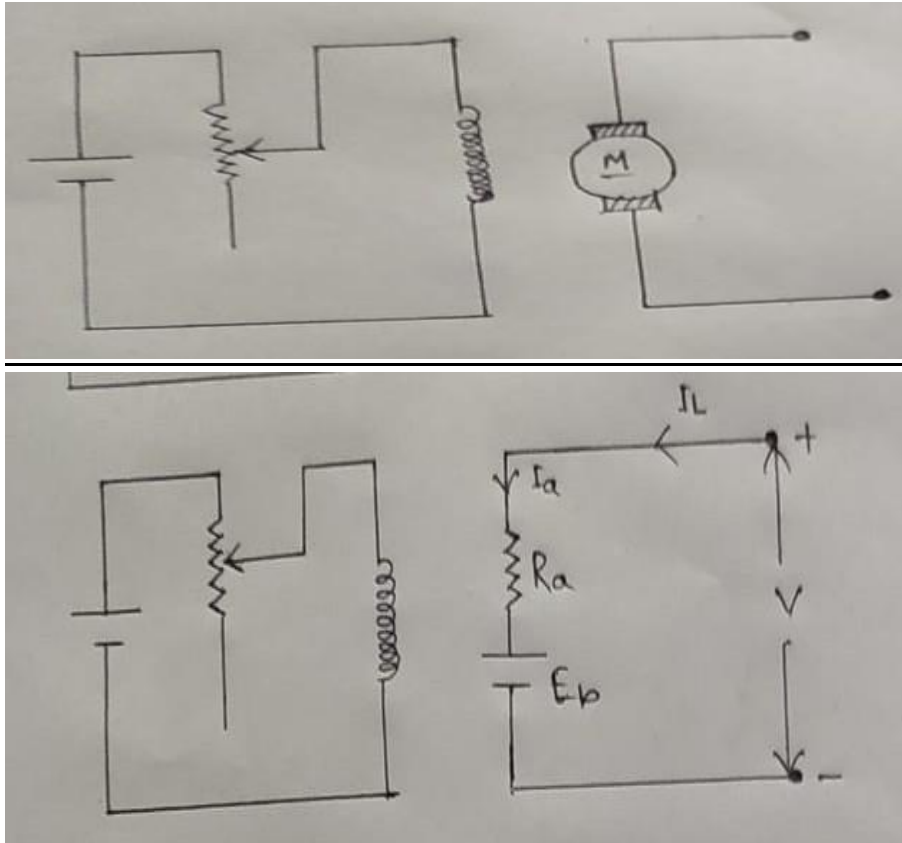

- ⇒ Applying KVL to the above closed circuit we get

$$\text{i. } -I_a R_a - E_b - 2 V_b + V = 0$$
$$E_b = V - I_a R_a - 2 V_b$$

$$\text{ii. } I_a = I_L$$

## self excited DC motor:

- if the field windings of a DC motor are excited or energised by the current produced of its own it is said to be self excited DC motor.
- It is three types

### i. DC shunt motor:

- if the field windings of a self excited DC motor are connected in parallel with the armature then it is called shunt motor

### symbol and circuit diagram

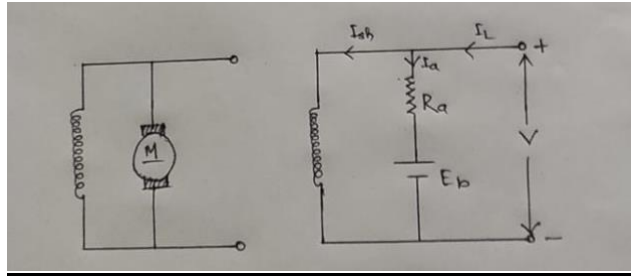

- i. applying KVL across the armature and supply voltage we get  

$$-I_a R_a - E_b - 2V_b + V = 0$$

$$E_b = V - I_a R_a - 2V_b \quad , \quad V$$
- ii. applying KVL across the armature and shunt field winding  

$$-I_a R_a - E_b - 2V_b + I_{sh} R_{sh} = 0$$

$$E_b = I_{sh} R_{sh} - I_a R_a - 2V_b$$
- iii. According KCL  

$$I_L = I_a + I_{sh}$$
- iv. Applying KVL to the circuit shunt field and supply voltage we get  

$$-V + I_{sh} R_{sh} = 0$$

$$V = I_{sh} R_{sh}$$

### DC series motor

If the field winding of a self excited DC motor are connected in series with the armature then it is called as DC series motor.

### Symbol and circuit diagram

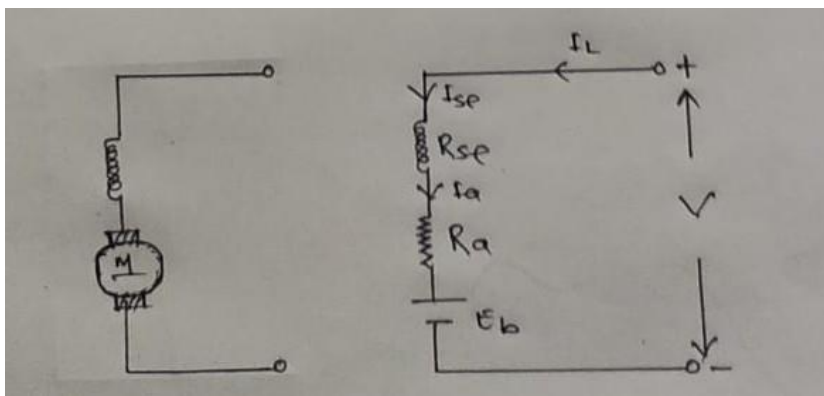

#### ⇒ Current relation

In above circuit

Voltage relation:

Applying KVL to circuit we get  $-V + E_b + I_a R_a + I_{se} R_{se} + 2V_b = 0$

$$\Rightarrow E_b = V - I_a R_a - I_{se} R_{se} - 2V_b$$

$$\Rightarrow E_b = V - I_a (R_a - R_{se}) - 2V_b$$

d. **DC compound motor** :

In a self excited dc motor , if shunt field and series field windings are simultaneously used then it is called as dc compound motor.

a. Long shunt compound motor:

In a compound motor if shunt field winding is connected across both series field and armature winding then it called as long shunt compound motor

**Symbols and circuit diagrams** :

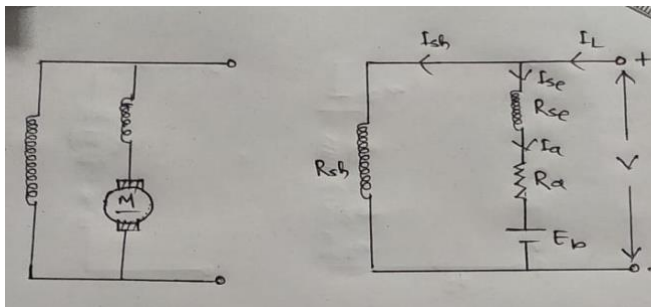

i. Current relation

$$I_a = I_{se}$$

$$I_a = I_L - I_{sh}$$

ii. Voltage relation

Applying KVL to the circuit armature and supplying voltage so we get,

$$-V + E_b + I_a R_a + I_{se} R_{se} + 2V_b = 0$$

$$\Rightarrow E_b = V - I_a R_a - I_{se} R_{se} - 2V_b \quad , V$$

$$\Rightarrow E_b = V - I_a (R_a - R_{se}) - 2V_b \quad , V$$

Applying KVL to the circuit armature and shunt field so we get

$$\Rightarrow -I_{se} R_{se} - I_a R_a - E_b + I_{sh} R_{sh} + 2V_b = 0$$

$$\Rightarrow E_b = I_{sh} R_{sh} - I_{se} R_{se} - I_a R_a - 2V_b \quad , V$$

$$\Rightarrow E_b = I_{sh} R_{sh} - I_a (R_{se} + R_a) - 2V_b \quad , V$$

Applying KVL to the circuit shunt field and supply voltage we get

$$-V + I_{sh} R_{sh} = 0$$

$$\Rightarrow V = I_{sh} R_{sh}$$

E. Short shunt compound motor

If the shunt field winding of a compound motor is connected across the armature only leaving the series field then it is called as shunt compound motor

Symbol and circuit diagram:

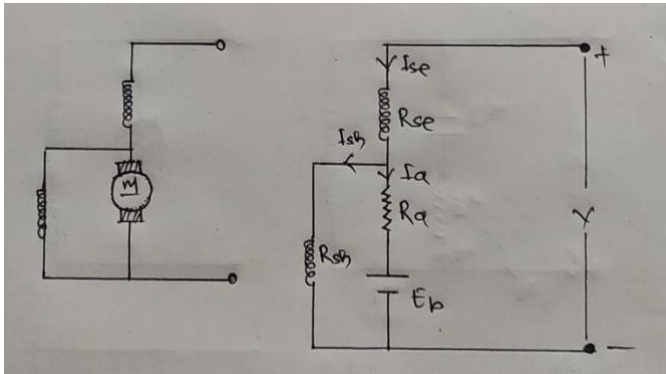

Current relation

- i.  $I_{se} = I_L$
- ii.  $I_a = I_{se} = I_L$

Voltage relation

Applying KVL to the circuit of armature and supply voltage

$$\begin{aligned} \Rightarrow -V + E_b + I_a R_a + I_{se} R_{se} + 2V_b &= 0 \\ \Rightarrow E_b &= V - I_a R_a - I_{se} R_{se} - 2V_b, V \end{aligned}$$

Applying KVL to circuit of supply voltage and shunt field

$$\begin{aligned} \Rightarrow -V + I_{sh} R_{sh} + I_{se} R_{se} &= 0 \\ \Rightarrow V &= I_{sh} R_{sh} + I_{se} R_{se}, V \end{aligned}$$

Applying KVL to the armature and shunt field

$$\begin{aligned} -I_a R_a - E_b - 2V_b + I_{sh} R_{sh} &= 0 \\ \Rightarrow E_b &= I_{sh} R_{sh} - I_a R_a - 2V_b, V \end{aligned}$$

### Types of compound motor :

Depending on the nature of winding on the magnetic pole a compound motor may be of cumulative motor differential motor.

### Cumulative compound motor:

The series field and shunt field windings are worked in a such a manner that flux produced from each winding if are added then it is called so in this motor resultant flux is increased.

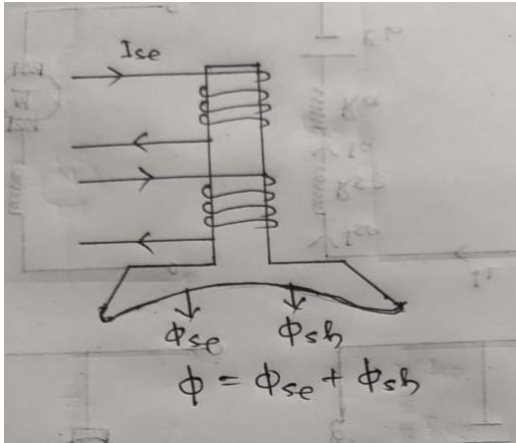

### Differential compound motor :

If two field winding are wound such a manner that the flux produced from them are opposite to each other. Then it is called as differential compound motor so in this motor resultant flux is decrease

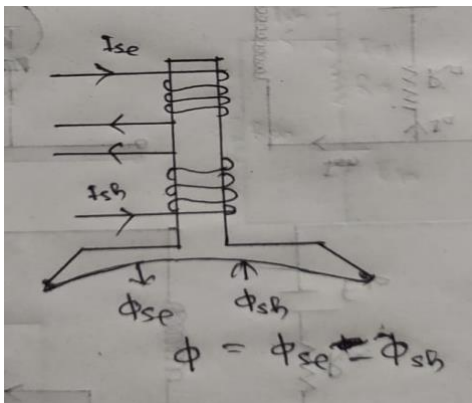

### 2.4 Torque equation of dc motor (Gross and shaft torque)

#### Torque

It is the twisting moment of a force about an axis its magnitude is the product of force F and radius (r)

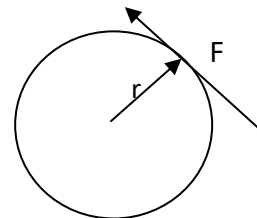

Mathematically

$$T = F \cdot r$$

Let in a dc motor  $r$  = radius of the armature in meter

$L$  = effective length of each conductor

$Z$  = total no of armature conductor

$A$  = no of parallel path

$I$  = flux per pole in weber.

$P$  = no of poles

$T_g$  = the gross of armature torque in N-m

The force

$$F = BIL$$

$$B = \phi / a$$

$$l = l_a / A$$

$$F = \frac{\phi}{a} \times \frac{l_a}{A} \times l$$

$$F = \frac{\phi I_a l}{a A}$$

torque in each conductor

$$T = FXr$$

$$= \frac{\phi I_a l}{a A} \times r$$

Where a = crosssectional area of the pole the crosssectional area per pole,

$$A = \frac{2\pi r l}{p}$$

$$T_g = \frac{\phi I_a l r}{a A}$$

$$= \frac{\phi I_a P}{2\pi A}$$

$$= T_g = \frac{1}{2\pi} \times \frac{p}{A} \times \phi I_a$$

$$= 0.159 \phi I_a (P/A)$$

Total conductor of torque.

$$T_g = 0.159 \times \phi I_a \times \frac{P}{A}$$

$T_g \propto I_a$  and all other are constant.

Another expression for Torque.

We know

$$E_b = \frac{\phi z N}{60} \times \frac{P}{A}$$

$$= \frac{\phi z P}{A} = \frac{E_b \times 60}{N}$$

Now put value of  $\frac{\phi z P}{A}$  in the eq -1 we get

$$T_g = 0.159 \times I_a \times \frac{E_b \times 60}{N}$$

$$T_g = 9.55 \times \frac{E_b \times I_a}{N} \text{ N-m}$$

### Shaft torque

The torque which is available at the motor shaft from doing usefull work is known as shaft torque.

- It is represented by  $I_{sh}$
- Shaft torque is less than the armature torque.

$$I_{sh} = \frac{9.55 \times POWER}{N} \quad \text{N-m}$$

$$T_{sh} = 9.55 \times \frac{P_{sh}}{N} \quad \text{N-m}$$

Where  $P_{sh}$  the shaft output power.

### Speed regulation

It is defined as the ratio between drop in speed ( from no load to full load ) and full load speed.

It is calculated in percentage

Mathematically

$$\% R = \frac{\text{no load speed} - \text{full load speed}}{\text{full load speed}} \times 100$$

$$\text{i.e } \% R = \frac{N_0 - N}{N} \times 100$$

### Speed relations:

Let  $E_{b1}$  = Back emf of a motor in 1st case

$E_{b2}$  = back emf motor on 2<sup>nd</sup> case

$N_1$  = speed of motor in first case

$N_2$  = speed of motor in 2<sup>nd</sup> case

$\Phi_1$  = flux / pole in 1<sup>st</sup> case

$\Phi_2$  = flux/ pole in 2<sup>nd</sup> case.

we know that

$$E_b \propto \phi N$$

In 1<sup>st</sup> case  $E_{b1}$ ,  $E_{b1} \propto \phi_1 N_1$

In 2<sup>nd</sup> case  $E_{b2} \propto \phi_2 N_2$

$$\Rightarrow \frac{E_{b2}}{E_{b1}} = \frac{\phi_2 N_2}{\phi_1 N_1}$$

$\Phi_1 = \Phi_2 = \Phi$  constant for DC shunt motor.

$\Phi \propto I_a$  in case of series motor.

### **Problem -1**

A 4 pole 500 v shunt motor has 720 wave connected in the armature. The full load armature current is 60 A and the flux per pole is 03wb the armature resistance is 2Ω and the contact drop  $I_v$  per brush calculate the full load speed of the motor.

Data given

$$P=4$$

$$V=500\text{v}$$

$$I_a= 60\text{A}$$

$$Z=720$$

$$A=2$$

$$\phi =03 \text{ wb}$$

$$R_a= .2 \Omega$$

$$2v_b= 2$$

Required data

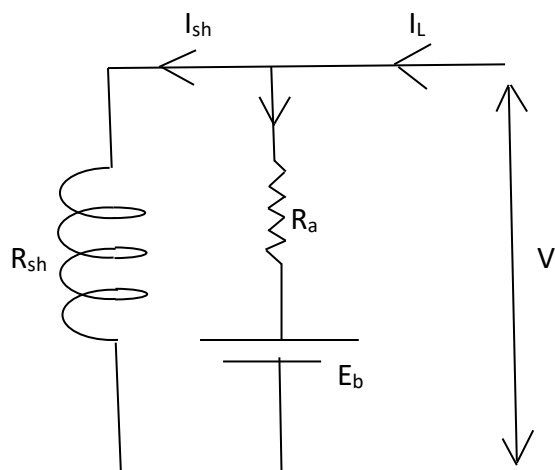

$$N= ?$$

Solution

We know for shunt motor

$$\begin{aligned} E_b &= V - I_a R_a - 2 v_b \\ &= 500 - 60 \times 0.2 - 2 \\ &= 486\text{v} \end{aligned}$$

For emf equation we know that

$$E_b = \frac{\phi Z N P}{60 A}$$

$$\begin{aligned} N &= \frac{E_b \times 60 \times A}{\phi \times Z \times P} \\ &= \frac{486 \times 60 \times 2}{0.03 \times 720 \times 4} \end{aligned}$$

$$= 675 \text{ rpm} \quad \text{Ans}$$

**Q-2** An armature of a DC motor has 774 conductors ,two parallel path 24 mub flux per pole. Armature current 50 A. the motor has 4 pole calculate the torque.

**Ans-** data given

$$Z= 774$$

$$\phi= 24 \text{ Mub}$$

$$= 24 \times 10^{-3} \text{ wb}$$

$$I_a = 50 \text{ A}$$

$$A = 2$$

$$P = 4$$

Required data

$$T_a = T_g = ?$$

$$T_g = 0.159 \phi z I_a (P/A)$$

$$= 0.159 \times 24 \times 10^{-3} \times 774 \times 50 \times \frac{4}{2}$$

$$= 295.35 \text{ N-m} \quad \text{Ans}$$

Q- 3

A 220 V DC shunt motor runs at 500rpm, when armature current is 50A. calculate the speed if the torque is doubled given that  $R_a = 0.2\Omega$

Given data

A shunt motor

$$V = 220 \text{ v}$$

$$N_1 = 500 \text{ rpm, when } I_{a1} = 50 \text{ A}$$

Required data

$$N_2 = ? \text{ when } T_2 = 2T_1$$

Solution

From figure-1

$$E_{b1} = V - I_{a1} R_a$$

$$= 220 - (50 \times 0.2)$$

$$= 220 - 10$$

$$= 210 \text{ V}$$

From figure-2

We know that

$$T \propto \phi I_a$$

$$\Rightarrow T \propto \phi_1 I_{a1}$$

$$\Rightarrow T_1 \propto \phi_1 I_{a1}$$

$$\Rightarrow T_2 \propto \phi_2 I_{a2}$$

$$\Rightarrow \frac{T_2}{T_1} = \frac{\phi_2 I_{a2}}{\phi_1 I_{a1}}$$

Here

$$\phi_1 = \phi_2$$

$$\text{so } \frac{T_2}{T_1} = \frac{I_{a2}}{I_{a1}}$$

$$\Rightarrow I_{a2} = \frac{T_2}{T_1} \times I_{a1}$$

$$\Rightarrow 2 \times 50$$

$$\Rightarrow I_{a2} = 100 \text{ A}$$

Hence

$$E_{b2} = V - I_{a2} R_a$$

$$= 220 - 100 \times 0.2$$

$$= 200 \text{ V}$$

We know that

$$\Rightarrow \frac{Eb_2}{Eb_1} = \frac{\phi_2 N_2}{\phi_1 N_1}$$

Here  $\phi_2 = \phi_1$

$$\Rightarrow N_2 = \frac{Eb_2}{Eb_1} \times N_1$$

$$\Rightarrow \frac{200}{210} \times 500$$

$$\Rightarrow 476 \text{ rpm}$$

Q-4 A 500 V shunt motor runs at its normal speed of 250rpm when the armature current is 200A. the resistance of armature is 0.12  $\Omega$  calculate the speed when a resistance is inserted in the field reducing the shunt field to 80% of normal value and the armature current is 100A.

Data given

DC shunt motor

V=500 v

$N_1 = 250 \text{ rpm}$

$I_{a1} = 200 \text{ A}$

$R_a = 0.12 \Omega$

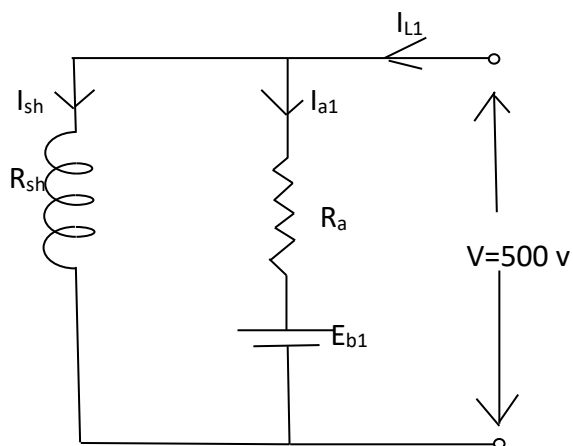

Required data

$N_2 = ?$

When  $\phi_2 = 0.8 \phi_1$

And  $I_{a2} = 100 \text{ A}$

From figure-1

$$E_{b1} = V - I_{a1} R_a$$

$$= 500 - 200 \times 0.12$$

$$= 476 \text{ v}$$

From figure-2

$$E_{b2} = V - I_{a2} R_a$$

$$= 500 - 100 \times 0.12$$

We know that

$$\begin{aligned} \frac{Eb_2}{Eb_1} &= \frac{\phi_2 N_2}{\phi_1 N_1} \\ \Rightarrow N_2 &= \frac{Eb_2}{Eb_1} \times \frac{\phi_1}{\phi_2} \times N_1 \\ \Rightarrow \frac{488}{476} \times \frac{1}{0.8} \times 250 \\ \Rightarrow N_2 &= 320 \text{ rpm} \end{aligned}$$

Q-5

Determine developed torque and shaft of 220v , 4 pole series motor with 800 conductor wave connected supplying a load of 802 kw by taking 45 A from the mains. The flux per pole is 250 Mub and its armature circuit resistance is 0.6Ω

Given data

DC series motor

$$V=220V$$

$$P=4$$

$$Z=800$$

$$I_L=45 \text{ A}$$

$$\phi = 250 \text{ mwb}$$

$$=0.025 \text{ wb}$$

$$R_{se} + R_a = 0.6 \Omega$$

$$A=2$$

$$P_0=8.2 \text{ KW}$$

Required data

$$T_g=?$$

$$T_{sh}=?$$

Solution

We know that

$$\begin{aligned} T_g &= \frac{1}{2\pi} \phi Z I_a \left( \frac{P}{A} \right) \\ &= 0.159 \phi Z I_a (P/A) \\ &= 0.159 \times 0.025 \times 800 \times 45 \times \frac{4}{2} \\ &= 286.4 \text{ N-m} \\ E_b &= V - I_a R_a - I_{se} R_{se} \\ &= V - I_a (R_a + R_{se}) \quad [I_a = I_{se}] \\ &= 220 - 45 \times 0.6 \\ &= 193 \text{ V} \end{aligned}$$

$$\begin{aligned} E_b &= \frac{\phi Z N}{60} \times \frac{P}{A} \\ 193 &= \frac{0.025 \times 800 \times N}{60} \times \frac{4}{2} \end{aligned}$$

$$N = \frac{193 \times 60 \times 2}{0.025 \times 800 \times 4}$$

We know that

$$P_o = \frac{2\pi N}{60} X T_{sh}$$

$$T_{sh} = \frac{P_o X 60}{2\pi N} = \frac{8.2 X 10^3 X 60}{2\pi X 289.5}$$

$$= 270.48 \text{ N-m}$$

Q-6

A 100 HP 500 v shunt motor has poles and a two circuit wave winding with 492 armature conductor the flux is 50 mwb per poles the full load efficiency 92 % the armature and the commutator field windings have a total resistance of 1  $\Omega$  the shunt field resistance is 250  $\Omega$  Calculate for full load speed and useful torque.

Data given

$$P_o = 100 \text{ hp} = 100 \times 746$$

$$= 74600 \text{ watt}$$

$$V = 500 \text{ v}$$

$$Z = 492$$

$$R_a = 0.1 \Omega$$

$$\phi = 50 \text{ mwb}$$

$$R_{sh} = 250 \Omega$$

$$\eta = 92\%$$

$$P = 4$$

$$A = 2$$

Required data

$$N = ?$$

$$T_{sh} = ?$$

Solution

$$\eta = \frac{o/p}{i/p}$$

$$= i/p = \frac{o}{\eta}$$

$$= \frac{74600}{0.92}$$

$$\text{Input} = 81087 \text{ watt}$$

$$\Rightarrow VI = 81087$$

$$\Rightarrow I = 81087/500$$

$$= 162.17 \text{ A}$$

In shunt motor

$$I_{sh} R_{sh} = V$$

$$\Rightarrow I_{sh} = \frac{V}{R_{sh}}$$

$$= \frac{500}{250}$$

$$= 2 \text{ A}$$

$$I_a = I - I_{sh}$$

$$= 162.17 - 2$$

$$= 160.17 \text{ A}$$

$$E_b = V - I_a R_a$$

$$= 500 - 160.17 \times 0.1$$

$$= 484 \text{ v}$$

We know that

$$E_b = \frac{\phi z N}{60} X \frac{P}{A}$$

$$N = \frac{E_b X 60 X A}{\phi z P}$$

$$= \frac{484 X 60 X 2}{50 X 10^{-3} X 492 X 4}$$

= 590 rpm

$$T_{sh} = \frac{9.55 \times \left(\frac{P}{p}\right) \text{power}}{N}$$

$$= 9.55 \times \frac{74600}{590}$$

$$= 1207.5 \text{ N-m}$$

## 2.5 Characteristics of dc shunt motors and Application

Generally for each motor three important characteristics are seen such as

- Speed current characteristics
- Torque current characteristics
- Speed torque characteristics

### Speed current Characteristics of DC shunt motor

#### Definition

If armature current is taken along X-axis but speed along Y-axis then with two different values of armature current  $I_a$  and speed  $N$  a graph such plotted is called speed current characteristics

#### Explanation

We know that in a DC motor ,

$$E_b \propto \phi N$$

$$\rightarrow N \propto E_b / \phi$$

But  $\phi$  is constant normal shunt motor

$$\text{So } N = k(E_b)$$

$$N = k(v - I_a R)$$

When a DC motor runs at light load then current drawn by the armature ( $I_a$ ) is very small ,so the armature rotates at its rated speed.

If load on the motor is generally increased then armature current will increase but armature resistance drop ( $I_a R_a$ ) will increase but with very small value hence speed of the motor decreases slightly. Therefore a dc shunt motor is treated as an approximately a constant speed motor.

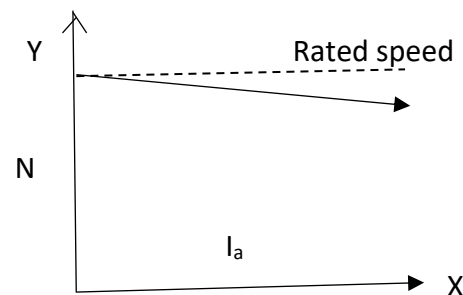

### Torque current characteristics

#### Definition

If armature current is taken along x-axis but torque along y-axis then with two different value of torque and current a graph such plotted is called as torque current characteristics.

### Explanation

We know that  $T \propto \phi I_a$   
In a shunt motor  
 $\Phi$  remains constant  
So  $T = k I_a$

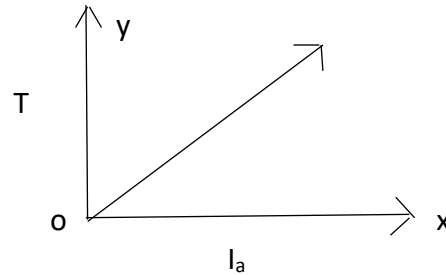

From the above relation it is clear that the graph is a straight line passing through the origin. Hence with increase of load on the motor armature current ( $I_a$ ) will increase their by increasing the torque proportionately.

### Speed torque characteristics

#### Definition

If torque is taken along x-axis but speed along y-axis then with different values of speed and torque a graph such plotted is called as speed torque characteristics.

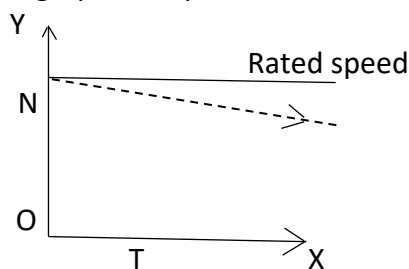

#### Explanation

When the motor runs at no load then armature current  $I_a$  assumed to be 0  
So torque  $T$  becomes 0 but speed  $N$  becomes maximum.  
As the total load on the motor goes on increasing very slightly as shown in the figure.

### Application of dc shunt motor .

- ⇒ Saw mills
- ⇒ Lathe machines
- ⇒ Press mills
- ⇒ Conveyor belts

### Characteristics of a DC series motor

#### i. speed current characteristics

if the armature current is taken along X-axis but speed along Y-axis then with different values of armature current ( $I_a$ ) and speed ( $N$ ) a graph such plotted is called as speed current characteristics

#### Explanation

We know that

$$E_b \propto \phi N$$

$$\Rightarrow N \propto \frac{E_b}{\phi}$$

But in a DC series motor  $\phi \propto I_a$

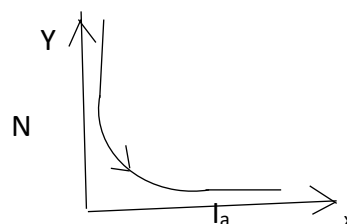

$$\text{Hence } N \propto \frac{E_b}{\phi}$$

$$\Rightarrow N \propto \frac{V - I_a R_a}{I_a}$$

$$\Rightarrow N = \frac{k}{I_a}$$

In the above relation it is clear that speed (N) is inversely proportional to the armature current ( $I_a$ ) So in light load the dc motor rotates at enormously high speed, it creates racing problem hence it is advisable.

### Torque current characteristics

If the armature current is taken along x-axis but torque (T) along Y-axis then with different values of armature current ( $I_a$ ) and torque (T) a graph such plotted is called as torque current characteristics.

### Explanations

We know that

$$T \propto I_a$$

But I series motor

$$\Phi \propto I_a$$

$$\Rightarrow T \propto I_a^2$$

$$\Rightarrow T = K I_a^2$$

$$\Rightarrow I_a^2 = k T$$

at the time of starting and from the above equation it is clear that the graph is a parabola symmetrical about Y- axis. Hence with increases square of the current. This concept is there till the magnetic saturation.

Beyond the magnetic saturation even through current increases but flux remains constant. So that graph behaves like straight line so with increase of load armature current ( $I_a$ ) will increase and the torque (T) will also increase proportionately.

### Speed torque characteristics

If the torque (T) is taken along X-axis but speed N along Y-axis then with different values of speed N and torque T graph such plotted is called as speed torque characteristics.

### Explanation

In no load when armature current is assumed to be 0 then torque is 0 but speed is infinite.

As load on the motor is increased torque developed by the motor will also increase. But speed will decrease inversely as shown in the above figure.

### Conclusion

A dc series motor is treated as a variable speed motor.

### Applications

Due to its high starting torque it is used in

- i. Trolleys
- ii. Heavy cranes

**Characteristics of DC compound motors.**

We know in a cumulative motor series field flux ( $\phi_{sc}$ ) and shunt field flux ( $\phi_{sh}$ ) are added together. So net flux is increased .

Similarly in differential compound motor net flux is decreased.

**Speed current characteristics :**

If the armature current is taken along x-axis but speed along Y-axis then with different values of speed N and armature current ( $I_a$ ) a graph such plotted is called as speed current characteristics.

Explanation

We know that

$$N \propto \frac{Eb}{\phi}$$

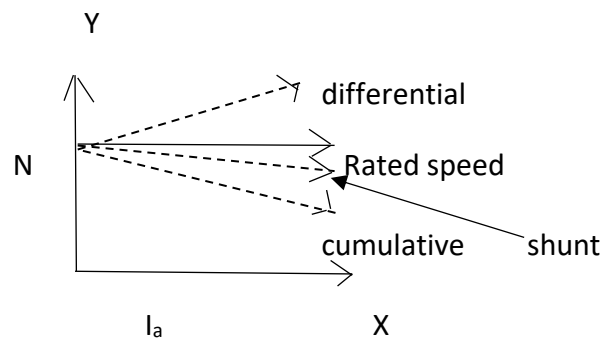

As we know that in a cumulative compound motor net flux is increased from the above relation it is understood that with increase of flux speed of the motor will decrease more than the speed of shunt motor .

In case of different compound motor since net flux is decreased. So speed of this motor will increase comparatively higher the speed of shunt motor .

**Torque current characteristics**

If armature current ( $I_a$ ) is taken along X-axis but torque T is along Y-axis then with different values of armature current  $I_a$  and torque T a current such plotted is called torque current characteristics.

**Explanation**

We know that

$$T \propto \phi I_a$$

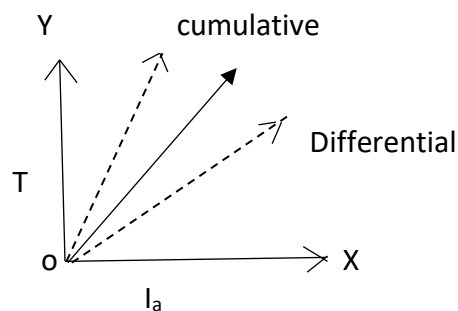

In case of cumulative compound motor since resultant flux is increased so from the above torque will also increase.

In case of differential compound motor since flux is decreased so the torque will also decreased.

### **Torque speed characteristics :**

If torque  $T$  is taken along X-axis but speed  $N$  along Y- axis then with different values of torque  $T$  and speed  $N$  a graph such plotted is called as torque speed characteristics.

Explanations

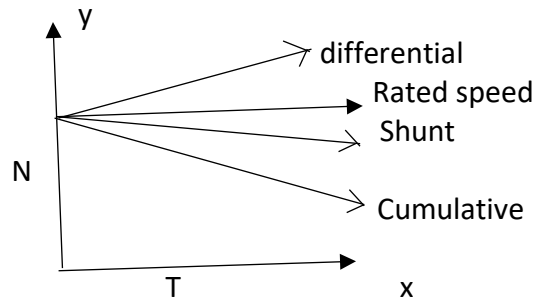

In differential compound motor with increase of load even though torque is decreased. But speed will increased. Similarly in case of cumulative compound motor with increase of torque speed will decrease as shown in above figure.

### **Conclusion**

A DC compound motor is treated as a partially variable speed motor.

### **Application**

It is used in

- i. drilling machines
- ii. punching machines
- iii. small cranes.

### **2.6 methods of starting of DC motors**

We know that

$$E_b = V - I_a R_a$$

$$\Rightarrow I_a R_a = V - E_b$$

$$\Rightarrow I_a = \frac{V - E_b}{R_a}$$

At this time of starting of DC motor speed  $N$  is zero. Since  $E_b \propto N$  then  $E_b$  become zero at this time of starting.

In this equation of  $E_b$  and we know value of  $R_a$  is very very small so armature current will become dangerously high. Hence to limit such heavy current at the time of starting we use starters.

### **Starter:**

It is defined as a safety device which limits the starting current to a safe value.

## Three -point stator and four-point stator/ static of DC motors by solid state converter

It is defined as a safety device which limits the starting current to a safe value.

Types of starter used in DC motors

Following are the important starter used for various DC motors.

- 3-point starter – for DC shunt motor
- 4 -point starter- for DC compound motor
- Drum controller starter-- for DC series motor

### 3-point stator

#### Definition

The three point stator is mostly used for starting shunt motor and minimize the starting current.

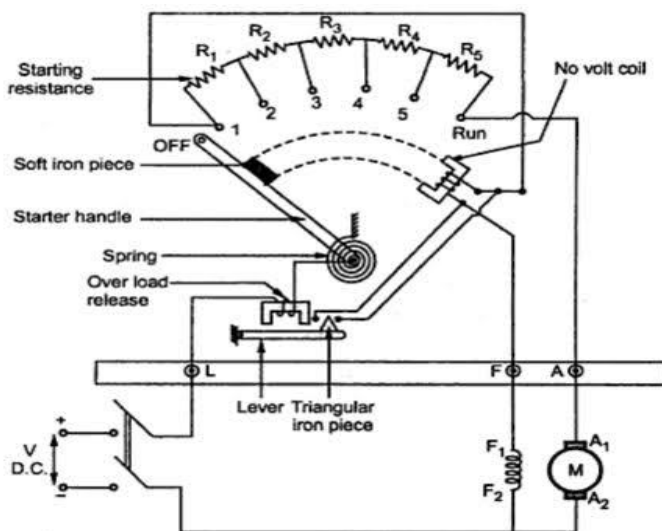
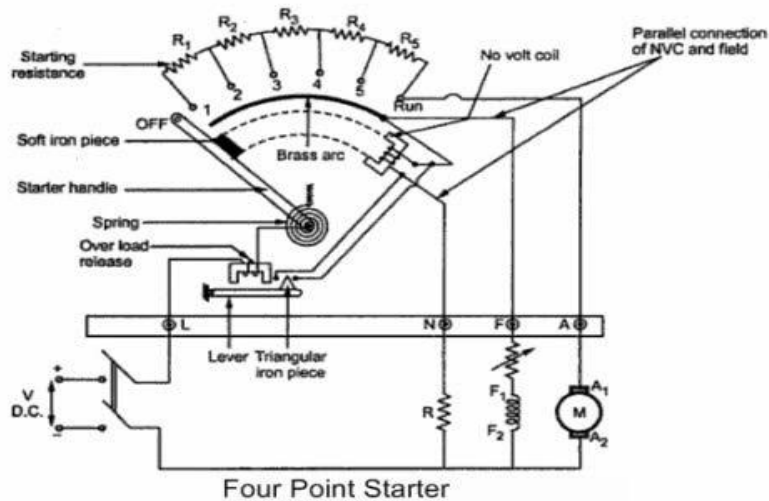

Figure shows the schematic diagram of a three point starter for a shunt motor it has three terminals namely L,Z and A .

The starter resistance divided into several sections and connected in series with the armature. The tapping points of the starting studs. The three terminals L ,Z and A of the positive line terminal shunt field terminal and armature terminal. The other terminal of Z and A are connected to the negative terminal of the supply. The no-volt release coils connected in the shunt field circuit. One end of the handle is connected to the terminal L through over load release coil. The other end of the handle moves against a spiral spring and makes contact with each stud during starting operation cutting out more and more starting resistance as it passes each stud in clockwise direction.

### 4-point starter

The 4-point starter acts a protective device that helps in safe guarding the armature of the shunt or compound excited DC motor against the high starting current produced in the absence of back emf at starting.



### Explanation

Hence NVC is connected independently across the supply the fourth terminal called N in addition to the L , F and A so any change in the field supply current does not bring always produce a force at a hold against force of the spring under all the operational conditions. Such a current is adjusted through No voltage coil.

With help of fixed resistance R connected is series with the NVC using fourth point N as shown in the above figure.

When handle is taken to stud no 1 and supply is given circuits is found to be closed and current starts flowing in the following manner.

1. 1<sup>st</sup> point flows through the starting resistance (  $R_1+R_2+R_3+.....$ ) and then to the armature.
2. 2<sup>nd</sup> point flows through the soil windings
3. 3<sup>rd</sup> point flows through the NVC in series with the protective resistance R  
electromagnetic pole is subjected upon the soft iron bar of the handle by the NVC which should be high enough to keep the handle of its running position or rather of its running position or rather prevent the spring the from restoring the handle at its original position.

### Drum controller starter

It is defined as a protective device in which used for the smoothly starting

### Explanation

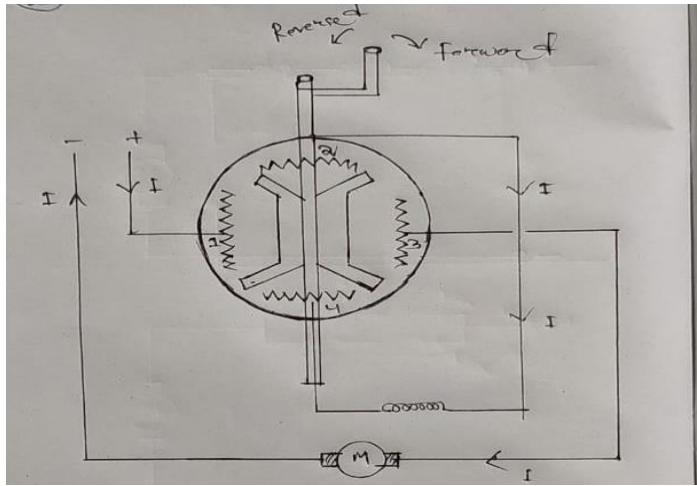

Since this starter looks like a drum so its name is drum controller starter. It has four resistance sections. A central rod or lever attached with four iron segments as shown in the figure and a handle at its top so that it can in forward as well as reverse direction.

When DC supply is given through the starter the handle is also moves in forward direction then the current will flow through resistor-1- resistor-2 series field resistor-4 - resistor-3 and to the armature. Now step by step the handle is moved in forward direction till it reaches in ON position.

When handle is moved in reverse direction then the current will flow through resistor-3- resistor-4 -series field – resistor-3-resistor-2 and then to the armature. Here direction of field current is observed to be reversed. Hence the motor will rotate in reverse direction.

- Basically this starter used in DC series motor.

## 2.7 speed control of dc motor

### Speed control of dc motor by field control method Speed of dc motor by armature control method

Speed control of dc motors

We know that speed of a dc motor

$$N \propto \frac{Eb}{\phi}$$

$$\Rightarrow N \propto \left( \frac{V - I_a R_a}{\phi} \right)$$

The speed of a motor depends on applied voltage (v) ,field flux ( $\phi$ ) and armature voltage drop ( $I_a R_a$ ) .so controlling these three important factors we can regulate ,the speed of a dc motor.

### Speed control of DC shunt motor:

#### a. Field or flux control method:

### Explanation

A dc ammeter and a rheostat are connected in series with the shunt field winding as shown in the above figure

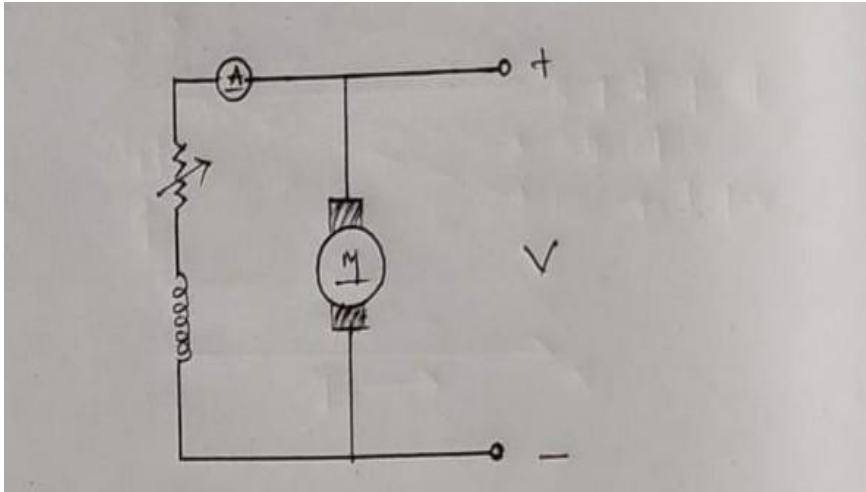

We know that  $N \propto 1/\phi$

When the rheostat value is kept maximum point or position then field circuit resistance gets increase so current through the field winding will decrease. Hence flux produced from the field will also decrease.

When rheostat value is decreased and field current is increased then flux produced from the pole will also increase. In the above relation with increase of flux speed of the motor gets decreased.

### B . Armature control method

It is defined as a method in which speed is controlled by controlling the armature current.

#### Explanation

We know

$$N \propto \frac{Eb}{\phi}$$

$$\Rightarrow N = k(V - I_a R_a)$$

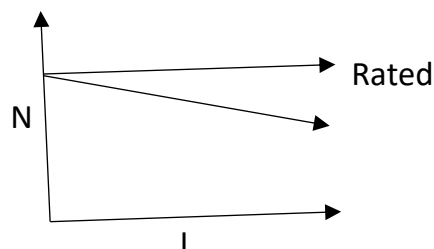

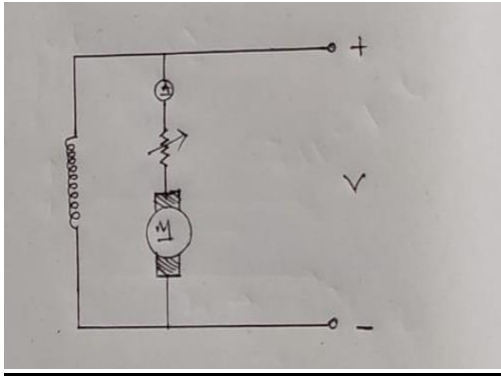

In this control method , a variable resistor and a DC ammeter are connected in series with the armature as shown in the figure

When rheostat value is gradually decreased then armature current ( $I_a$ ) will increase. Due to this increase of armature current armature resistance drop will also increase from the above drop will also increase from the above relation understood that with increase of drop , speed of the motor will decrease from its rated value. Hence this method is very useful where speed lower than the rated speed is necessary.

### **C . Voltage control Method OR**

#### **Ward -Leonard control method:**

#### **Definition**

It is defined as a control method in which speed of a motor is controlled by changing the supplied voltage.

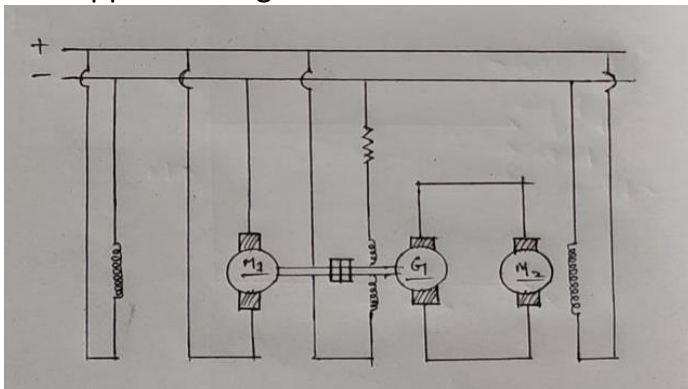

In this method a M-G set is used. Here as shown in the above figure , the speed of motor ( $M_2$ ) has to be controlled. So it gets supply from generator ( $G$ ) , but the generator is driven by the motor ( $M_1$ ). The motor  $M_1$  is connected to a DC supply. Once the motor  $M_1$  starts running then the generator ( $G$ ) will also starts rotating. At this time by decreasing the rheostat value of its field winding, field current is made increased. So field flux will also increase by which generated emf will increase. Hence supplied voltage to the motor  $M_2$  increase and therefore speed of motor  $M_2$  will increase.

Similarly by increasing rheostat value of the field winding of the generator , speed of motor  $M_2$  can be decreased.

The main advantage of this system is we can obtain the speed of motor, M2 in both the direction by reversing the field current of dc generator.

Q-1

A 250 V, DC shunt motor has armature resistance of  $0.25 \Omega$ . On load it takes an armature current of 50 A and runs at 750 rpm. If the flux of motor is reduced by 10% without changing the load torque, find the new speed of the motor.

Given data

A DC shunt motor

$V = 250 \text{ V}$

$R_a = 0.25 \Omega$

$I_{a1} = 50 \text{ A}$

$N_1 = 750 \text{ rpm}$

$\phi_2 = 0.9\phi_1$

$T_1 = T_2$

Required data

$N_2 = ?$

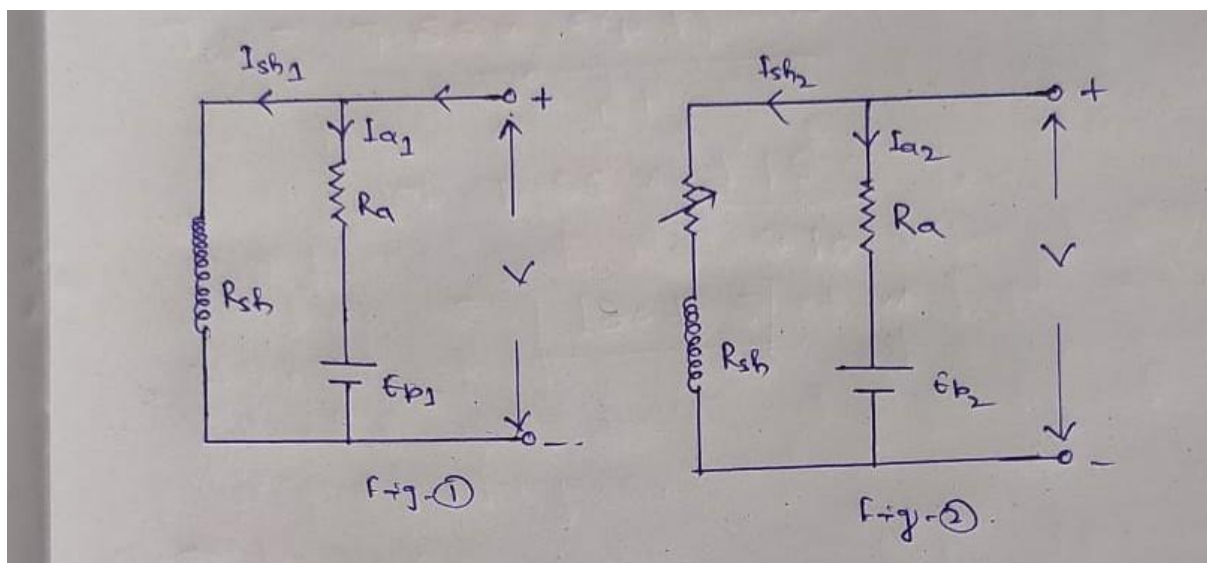

From figure-1

Back emf

$$\begin{aligned} E_{b1} &= V - I_{a1}R_a \\ &= 250 - 50 \times 0.25 \\ &= 237.5 \text{ v} \end{aligned}$$

From figure-2

Back emf

$$E_{b2} = V - I_{a2}R_a$$

We know that  $T_1 = T_2$

$$\Rightarrow \phi_1 I_{a1} = \phi_2 I_{a2}$$

$$\Rightarrow I_{a2} = \frac{\phi_1}{\phi_2} \times I_{a1}$$

$$\Rightarrow I_{a2} = \frac{1}{0.9} \times 50$$

$$\Rightarrow I_{a2} = 55.56 \text{ A}$$

Again  $E_{b2} = V - I_{a2}R_a$

$$= 250 - 55.56 \times 0.25$$

$$= 236.1 \text{ V}$$

We have

$$\frac{E_{b2}}{E_{b1}} = \frac{\phi_1 N_2}{\phi_1 N_1}$$

$$\Rightarrow N_2 = \frac{E_{b2}}{E_{b1}} \times \frac{\phi_1}{\phi_2} \times N_1$$

$$\Rightarrow N = \frac{236.1}{237.5} \times \frac{1}{0.9} \times 750$$

$$= 828.42 \text{ RPM}$$

Q-2

A 230 v dc shunt motor runs at 800 rpm and takes armature current of 50 A . find resistance to be added to the field circuit to increase speed to 100 rpm at an armature current of 80 A assume flux proportional to field current. Armature resistance =0.15  $\Omega$  and field winding resistance =250 $\Omega$  .

Given data

A dc shunt motor

$$V = 230 \text{ V}$$

$$N_1 = 800 \text{ rpm}$$

$$I_{a1} = 80 \text{ A}$$

$$N_2 = 1000 \text{ RPM}$$

$$R_a = 0.15 \Omega$$

$$R_{sh} = 250 \Omega$$

Solution

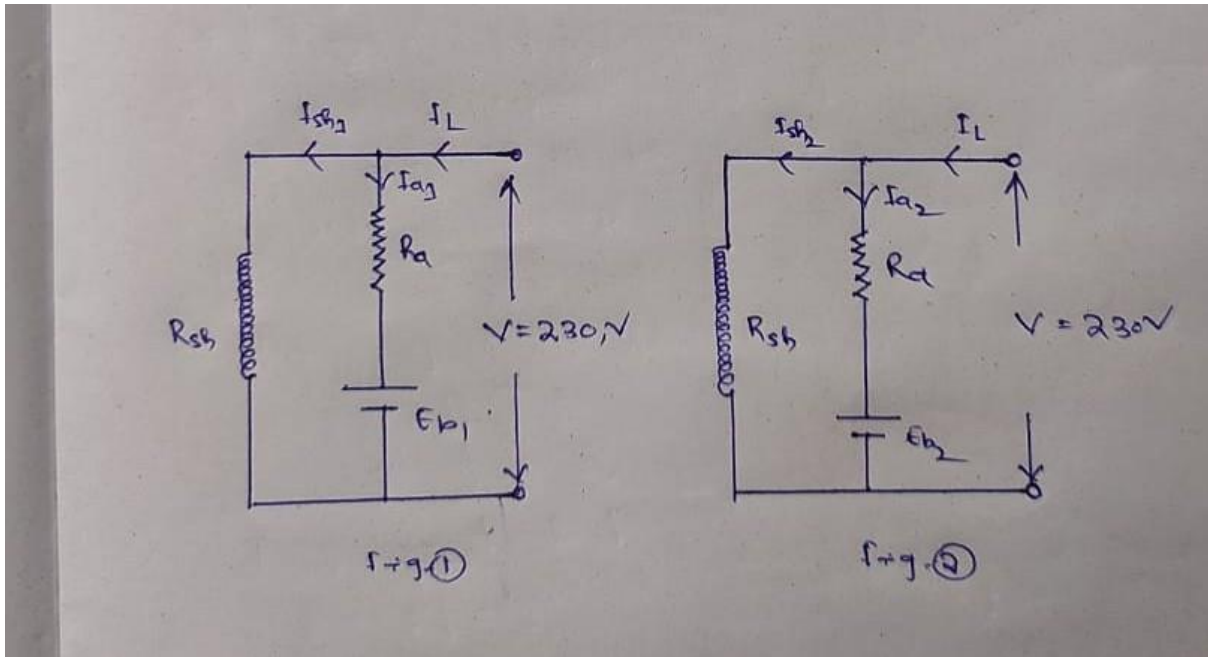

From Figure-1

Back emf

$$\begin{aligned}
 E_{b1} &= V - I_{a1}R_a \\
 &= 230 - (50 \times 0.15) \\
 &= 222.5 \text{ , v}
 \end{aligned}$$

From figure-2

Back emf

$$\begin{aligned}
 E_{b2} &= V - I_{a2}R_a \\
 &= 230 - (80 \times 0.15) \\
 &= 218 \text{ , v}
 \end{aligned}$$

$$I_{sh} = V / R_{sh}$$

$$= 230 / 250$$

$$= 0.92 \text{ A}$$

Let  $R_t$  = total shunt resistance

$$= (250 + R)$$

Where R is the additional resistance

$$I_{sh2} = 230 / R_t$$

We know that ,

$$\begin{aligned}
 \frac{N_2}{N_1} &= \frac{E_{b2}}{E_{b1}} \times \frac{\phi_1}{\phi_2} \\
 &= \frac{E_{b2}}{E_{b1}} \times \frac{I_{sh1}}{I_{sh2}} \quad \text{since flux } \propto \text{ field current} \\
 &= \frac{218}{222.5} \times \frac{0.92}{\frac{230}{R_t}}
 \end{aligned}$$

$$R_t = \frac{N_2 E b_1 V}{N_1 E b_2 I_{sh1}}$$

$$= \frac{1000 \times 22.5 \times 230}{800 \times 218 \times 0.92}$$

$$= 319 \Omega$$

$$R = R_t - 250$$

$$= 319 - 250$$

$$= 69 \Omega$$

$$I_{sh2} = \frac{V}{R_t}$$

$$= \frac{230}{319}$$

$$= 0.721 \text{ , A}$$

Ratio of torque in two cases

$$T_2/T_1 = \frac{I_{sh2} I_{a2}}{I_{sh1} I_{a1}}$$

$$= \frac{0.721 \times 80}{0.92 \times 50}$$

$$= 1.254$$

## 2.8 Speed control of DC series motor:

### A. Flux or field control method

Definition

It is defined as a control method in which we can regulate the speed of motor by controlling the field flux. Sometimes it is also called as field diverter method.

Explanation

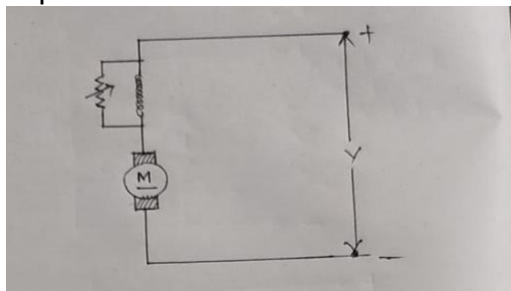

We know that

$$N \propto \frac{Eb}{\phi}$$

In this method a variable resistance is connected across the series field winding. This resistor is also called as diverter resistor. If diverter current is increased then less current will flow through it but more current through the field winding. So more flux is produced from the field. Hence speed will decrease.

Similarly by decreasing the rheostat value speed of the value can be increased.

### a. Armature diverter method

It is defined as a speed control method in which a variable resistor so called divertor is connected across the armature.

### Explanation

In this method a variable resistor is connected across the armature circuit. So this variable resistor is also called as divertor resistance.

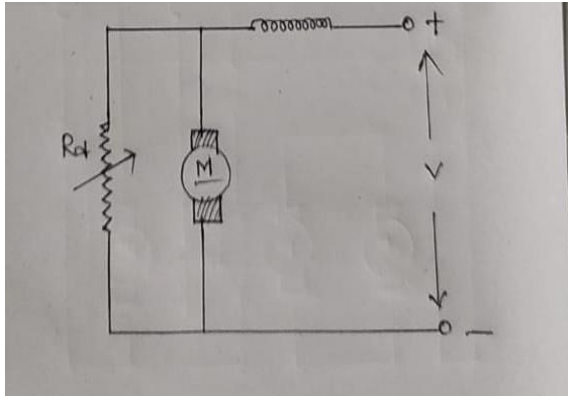

When divertor resistance is made increased, less current will flow through it but more armature. Due to more armature current, armature resistance drop ( $I_a R_a$ ) will also increase but speed of the motor will decrease from its rated value.

### b. Series parallel method

It is defined as a method in which speed of the motor is controlled by grouping the field winding in series paralleling fusion.

### Explanation

This is one of the convenient speed control method where we can get multiple of speeds.

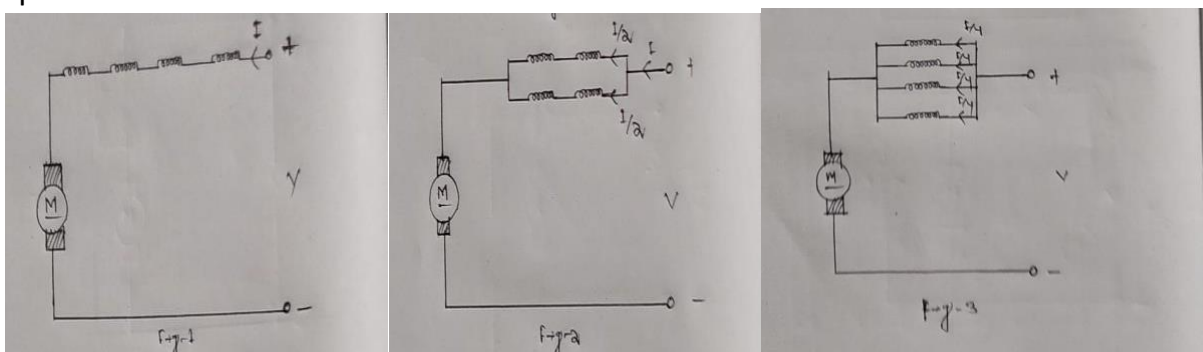

Let us consider 4 pole DC series motor as shown in figure-1

Let us arrange the series field winding in two parallel paths as shown in the figure-2

Here in each current has reduced to half accordingly flux is reduced to half so speed will become double of its initial speed.

Now arrange the series field in four parallel paths as shown in figure-1

Here current in each field has reduced quarter times, accordingly flux is also reduced quarter times but speed is increased four times of the initial speed.

By this way we can increase the speed of a DC series motor to some multiple.

### **2.9 Determination of efficiency of DC motors:**

To determine the efficiency of DC motors following tests are conducted.

1. Brake test
2. Swinburn's test

#### **Efficiency by Brake test method:**

It is one of the easiest method to determine efficiency of DC motors. But especially for series motors.

#### **Theory**

Let us take a water cooled pulley and mounted on the shaft of the motor. A horizontal flat rod over which a load adjustment handle or wheel is fixed at its centre it is also supported by two vertical bars. Two spring balance are also attached with the hooks as shown in the figure. A canvas belt with grooves of the pulley. Two of its ends are fixed with two spring balances.

A DC voltmeter and ammeter are also connected at the input of this motor. After starting the motor, appropriate load is given to the pulley through load adjustment wheel. At this time the speed of armature is recorded by using tachometer. Similarly supplied voltage and current by voltmeter and ammeter.

#### **Derivation**

Let

$v$  = supplied voltage shown by the voltmeter

$I$  = supplied current shown by the ammeter  $A$

$R$  = radius of the pulley,  $m$

$W_1$  &  $W_2$  = Weight shown by the spring balance,  $kgf$

$N$  = speed of the armature,  $rpm$

$T_{sh}$  = shaft torque,  $N\cdot m$

Effective weight on the pulley

$W = (W_1 - W_2)$ ,  $kgf$

$= 9.81 (w_1 - w_2)$   $N$

Hence shaft torque  $= T_{sh} = W \times R$   $N\cdot m$

So output power  $P_0 = \frac{2\pi N}{60} T_{sh}$   $W$

But input power,  $P_i = VI$   $W$

Efficiency of the motor,

$$\Rightarrow \eta = \frac{P_o}{P_i} \times 100$$

Q -1

The following readings are observed when doing a load test on DC shunt motor using brake drum.

Spring balance readings: 10 kg    35 kg

Diameter of drum: 40 cm

Speed of the motor: 950 RPM

Applied voltage : 200 V

Line current: 30 A

Calculate the output power and efficiency

**Given data**

A DC shunt motor

$W_1 = 10 \text{ kg}$

$W_2 = 35 \text{ kg}$

$D = 40 \text{ cm}$

$R = 20 = 0.2 \text{ m}$

$N = 950 \text{ Rpm}$

$V = 200 \text{ v}$

$I = 30 \text{ A}$

**Required data**

$P_o = ?$

$\eta = ?$

solution

effective weight of drum,

$W = W_2 - W_1$

$= 35 - 10$

$= 25 \text{ kg}$

$= 9.8 \times 25$

$$=245 \text{ N}$$

Radius of the drum

$$R=D/2$$

$$=40/2$$

$$=20 \text{ cm}$$

$$=0.2 \text{ m}$$

$$T_{sh}= W \times R$$

$$=245 \times 0.2$$

$$=49 \text{ N-m}$$

I. we know that output power

$$P_o = \frac{2\pi N}{60} \times T_{sh}$$

$$= \frac{2\pi \times 950}{60} \times 49$$

$$=4874.7 \text{ w}$$

$$=4.8747 \text{ KW}$$

II. efficiency of the motor

$$\eta = \frac{P_o}{P_i} \times 100$$

$$P_i = V \times I_L$$

$$=200 \times 30$$

$$=6000$$

$$\eta = \frac{4874.7}{6000} \times 100$$

$$=81.24 \%$$

Q-2

In a brake test the effective load on the branch pulley was 38.1 kg . the effective diameter of the pulley is 63.5 cm and speed is 12 rps the motor to 49 A at 220 v find out the power and efficiency at this load.

Data given

$$W_1 - W_2 = 38.1 \text{ kg}$$

$$= 38.1 \times 9.81$$

$$=373.76$$

$$\text{Diameter } d = 63.5 \text{ cm}$$

$$\text{Radius } R = 63.5/2 = 31.75$$

$$=0.3175 \text{ m}$$

$$\eta = 120 \text{ rps}$$

$$I = 49 \text{ A}$$

$$V = 220 \text{ V}$$

Required data

$$P_{out} = ?$$

$$\eta = ?$$

$$P_{out} = T_{sh} \omega$$

Shaft torque

$$T_{sh} = (W_1 - W_2) \times R$$

$$= 373.76 \times 0.3175$$

$$= 118.6 \text{ N-m}$$

$$P_{out} = T_{sh} \omega$$

$$= T_{sh} \times 2\pi n$$

$$= 118.6 \times 2\pi \times 12$$

$$= 8942.2 \text{ watt}$$

The i/p to the machine or motor

$$P_{in} = VI$$

$$= 220 \times 49$$

$$= 10780 \text{ w}$$

Efficiency of the motor,

$$\eta = \frac{\text{output}}{\text{input}} \times 100$$

$$= \frac{8942.2}{10780} \times 100$$

$$= 83 \%$$

## 2.10 Determination of Efficiency of dc motor by Swinburn's Test method:

This is also a suitable method to determine efficiency of DC motors which is explained before.

### Explanation

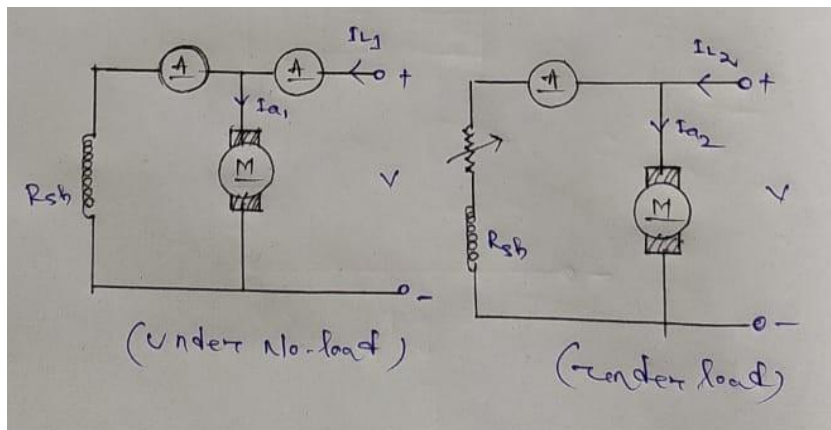

Under no load

Input power,

$$P_i = V I_{L1}$$

Output power,  $P_o = 0$

Total losses,  $W_T = P_i - P_o$

$$= VI_{L1}$$

$$W_c + W_v = VI_{L1}$$

$$W_c + I_{a1}^2 R_a = VI_L$$

$$W_c = VI_{L1} - I_a^2 R_a, W$$

Under load

Input power,  $P_i = VI_{L2}, w$

Variable loss,  $w_v = VI_a^2 R_a$

Total losses  $W_T = W_c = W_v$

$$= VI_{L1} = (VI_{L1} - I_{a1}^2 R_a) + I_{a2}^2 R_a$$

$$= \text{Power } P_o = (P_i - W_T)$$

$$= VI_{L2} - W_T$$

$$\text{Efficiency, } \eta = \frac{P_o}{P_i} \times 100$$

(Q) A 220V DC shunt motor at No-load takes a current of 2.5A. The resistance of armature is .8 shunt field resistance 200Ω. when the motor draw 32A. what is the efficiency.

Data Given

$$V = 220V$$

$$R_a = .8\Omega$$

$$I_0 = 2.5A$$

$$I = 32A$$

$$I_a = 2.5A$$

$$I = 32A$$

Required Data

$$\eta = ?$$

Sol<sup>n</sup> →

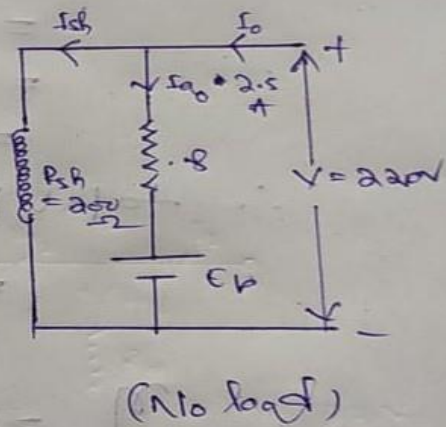
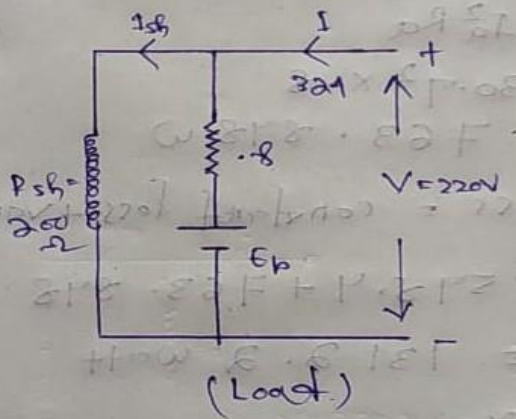

Case - 1

No load

$$I_{sh} = \frac{V}{R_{sh}} = \frac{220}{200} = 1.1A$$

$$I_a = I_0 - I_{sh}$$

$$= 2.5 - 1.1 = 1.4A$$

∴ Variable loss at load,

$$= \text{Armature copper loss} = I_a^2 R_a$$

$$= 1.4^2 \times .8$$

$$= 1.568W$$

∴ constant loss = No load i/p - variable loss

$$= \sqrt{I_0} - \text{variable loss}$$

$$= 220 \times 2.5 - 1.568$$

$$= 548.432 \text{ watt}$$

when motor draw 32 A

$$I_{sh} = \frac{V}{R_{sh}} = \frac{220}{200} = 1.1 \text{ A}$$

$$I_a = 32 - 1.1 = 30.9 \text{ A}$$

∴ Variable loss or Armature Cu. Loss

$$= I_a^2 R_a$$

$$= 30.9^2 \times 0.8$$

$$= 763.848 \text{ W}$$

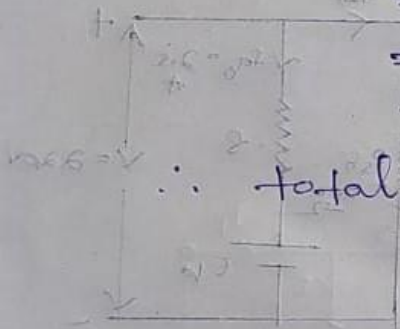

∴ total loss = constant loss + variable loss

$$= 548.4 + 763.848$$

$$= 1312.2 \text{ watt}$$

$$m = \frac{o/p}{i/p} \times 100$$

$$= \frac{i/p - \text{total loss}}{i/p} \times 100$$

$$= \frac{7040 - 1312.2}{7040} \times 100$$

$$= \frac{5727.8}{7040} \times 100$$

$$= \boxed{81.3 \%}$$

## 2.11 losses and power stage of dc motor and uses a dc motor

### Losses in dc motor

All the losses in motor are same as all the losses in generator.

### Efficiency of a dc motor

$$\text{Efficiency } \eta = \frac{\text{output}}{\text{input}} \times 100$$

### Condition for maximum efficiency

Variable loss = constant loss

### Power stage Diagram

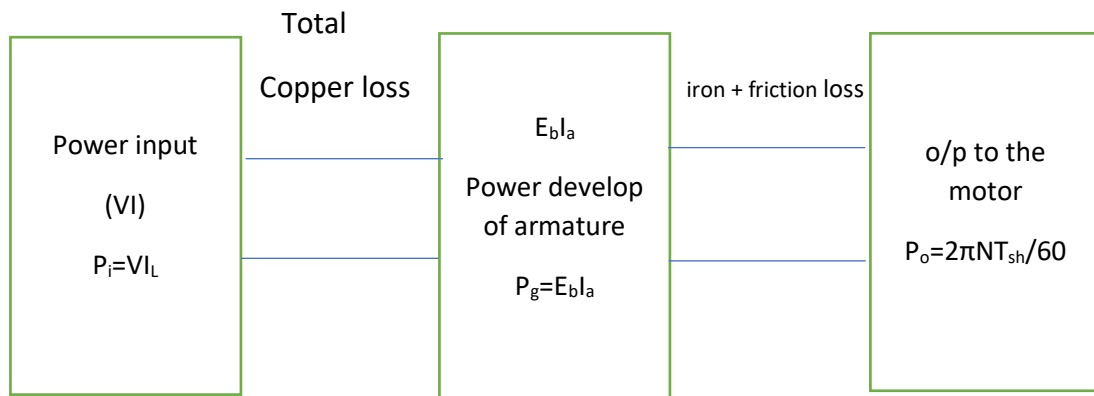

- Electrical efficiency =  $\eta_{\text{elect.}} = \frac{P_g}{P_i} \times 100$
- Mechanical efficiency =  $\eta_{\text{mech}} = \frac{P_o}{P_g} \times 100$
- Overall commercial standard efficiency =  $\eta = \frac{P_o}{P_i} \times 100$

## 2.12 numerical problem on losses and efficiency

(1) A 220V shunt motor takes a total current of 80A and runs at 800rpm. Shunt field resistance and armature resistances are 50Ω and 0.1Ω respectively. If a gross and friction loss = 1600W. Find the copper loss, Armature torque, shaft torque and efficiency.

Data Given

$$V = 220V$$

$$N = 800 \text{ rpm}$$

$$R_{sh} = 50\Omega$$

$$R_a = 0.1\Omega$$

$$I_L = 80A$$

gross and friction loss = 1600W.

Required data

$$I_a = ?$$

$$T_a = ?$$

$$T_{sh} = ?$$

$$\eta = ?$$

$$\text{Soln} \rightarrow 16 \times 220 = 3520$$

we know in shunt motor,

$$I_{sh} R_{sh} = V$$

$$I_{sh} = \frac{V}{R_{sh}}$$

$$= \frac{220}{50} = 4.4A$$

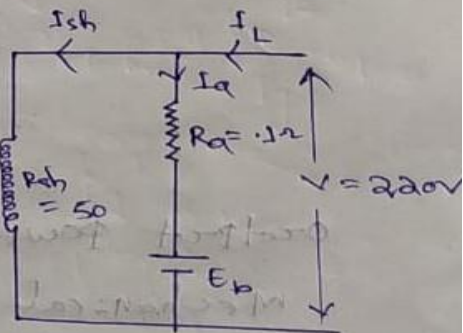

$$I_{sh} = 4.4 \text{ A}$$

$$I_a = I_L - I_{sh}$$

$$= 80 - 4.4$$

$$= 75.6 \text{ A}$$

$$\text{Shunt field copper loss} = I_{sh}^2 R_{sh}$$

$$= 4.4^2 \times 50$$

$$= 968 \text{ W}$$

$$\text{Armature copper loss} = I_a^2 R_a$$

$$= 75.6^2 \times 0.1$$

$$= 571.5 \text{ W}$$

$$\therefore \text{total c.c. loss of the motor} =$$

$$968 + 571.5$$

$$= \boxed{1539.5 \text{ watt}}$$

in a shunt motor

$$E_b = V - I_a R_a$$

$$= 200 - 75.6 \times 0.1$$

$$= 212.4 \text{ V}$$

Armature Torque,

$$T_a = 9.55 \times \frac{E_b I_a}{N}$$

$$= 9.55 \times \frac{212.4 \times 75.6}{800}$$

$$= \boxed{191.32 \text{ N.m}}$$

Output power,

Mechanical power developed - (Iron +

friction) loss

$$= E_b I_a - 1600$$

$$= 212 \times 75.6 - 1600$$

$$= 14457.4$$

$$\text{Shaft torque, } T_{sh} = 9.55 \times \frac{\text{output power}}{N}$$

$$= 9.55 \times \frac{14457.4}{800}$$

$$= \boxed{172.5, \text{ Nm}}$$

$$\text{Efficiency, } \eta = \frac{\text{output}}{\text{input}} \times 100$$

$$= \frac{14457}{220 \times 80} \times 100$$

$$= \boxed{82\%}$$

A 4 pole 250V series motor has a wave connected armature with 1254 conductors the flux per pole equal to 22 mwb when the motor is taking 50A. Iron and friction losses is 1kW.

Armature resistance  $1.2 \Omega$  series resistance  $0.2 \Omega$  calculate the speed the BHP the shaft torque and the Efficiency.

data given

$$P = 4$$

$$Z = 1254 \times 10^3$$

$$\phi = 22 \times 10^{-3}$$

$$\text{rotor friction loss} = 1 \text{ kW} = 1000 \text{ W}$$

$$R_a = 0.2 \Omega$$

$$R_{se} = 0.2 \Omega$$

$$V = 250 \text{ V}$$

$$I_L = 50 \text{ A}$$

$$I_L = I_a = I_{se} = 50 \text{ A}$$

Required data

$$N = ?$$

$$\eta = ?$$

Sol<sup>n</sup> → we know in series motor,

$$E_b = V - I_a R_a - I_{se} R_{se}$$

$$= 250 - 50 \times 0.2 - 50 \times 0.2$$

$$= 230 \text{ V}$$

$$E_b = \frac{\phi Z N}{60} \times \frac{P}{A}$$

$$N = \frac{E_b \times 60 \times A}{\phi \times Z \times P}$$

$$= \frac{230 \times 60 \times 2}{22 \times 10^{-3} \times 1254 \times 4}$$

$$= \boxed{250.4 \text{ rpm}}$$

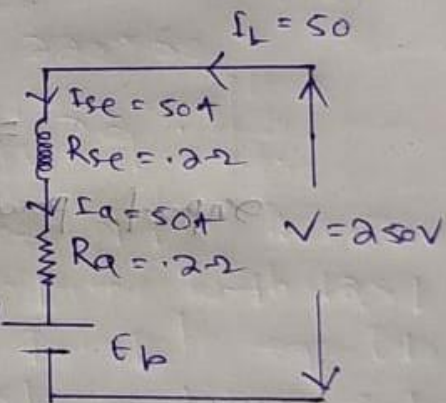

Mechanical power developed, <sup>(5)</sup>

$$= E_b \times I_a \quad P = 9$$

$$= 230 \times 50 = 11500 \text{ watt}$$

$$= 11500 \text{ watt}$$

Output of the motor, =

Mechanical power developed - friction +

friction loss

$$= 11500 - 1000$$

$$= 10500 \text{ watt}$$

$$\text{BHP} = \frac{10500}{746} = 14.07 \text{ hp}$$

$$T_{sh} = 9.55 \times \frac{\text{output power}}{N}$$

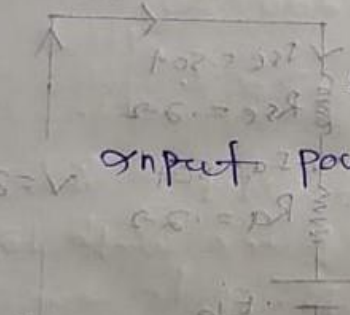

$$= 9.55 \times \frac{10500}{1500} = 67.1 \text{ Nm}$$

input power =

$$= 250 \times 50 =$$

$$= 12500$$

$$\text{Efficiency} = \frac{\text{output}}{\text{input}} \times 100$$

$$= \frac{10500}{12500} \times 100$$

$$= \boxed{84\%}$$

$$1.1 \times 1.261 \times 0.01 \times 56$$

$$1.1 \times 1.261 \times 0.01 \times 56$$

### Short questions with answer

Q-1

What is difference between the DC motor and generator answer in one line?

Ans : DC motor is an electrical machine which converts electrical energy into mechanical energy but DC generator does the reverse.

Q-2

What is back emf or counter emf of a dc motor?

Ans: the back emf is defined as an induced emf which opposes or counter paths the supplied voltage.

It is denoted by  $E_b$  and its unit is volt.

$$E_b = \frac{\phi Z N}{60} \left( \frac{p}{a} \right), v$$

Q-3

Write the voltage equation of a DC motor?

The voltage equation of a DC motor is

$$E_b = V - I_a R_a - 2V_b, v$$

Q-4

The term  $E_b$  is used in dc generator of motor?

The term  $E_b$  is used in DC motor.

Q-5

How can you reverse the direction of the armature of a dc motor?

Ans: The rotation of an armature of a DC motor can be reversed by inter changing the terminals either of armature or field circuit.

Q -6

If armature and field terminals are reversed then in which direction will the rotor of a dc motor rotate?

Ans: If armature and field terminals are reversed then there would be no change of direction of rotation of the armature.

Q-7

At what condition the power developed by a motor is maximum?

The power developed or delivered by a DC motor is maximum only when the back emf is half of the supplied voltage.

$$E_b = V/2$$

Q-8

Which DC motor is most suitable for electric traction?

Ans:

Dc series motor is most suitable for electrical traction.

Q-09

For lathe machines which DC motor is suitable?

Ans :Dc shunt motor is suitable for lathe machines.

Q -10

For drilling purposes which DC motor is used?

Ans: for drilling purposes DC compound motor is used.

Q-11

Which DC motor can be operated in a wide range of speed?

Ans : DC series motor can be operated in a wide range of speeds.

Q-12

Which DC motor gives high torque at the time of starting ?

Ans :

DC series motor gives high torque at the time of starting

### **Long question**

Q-1

Explain the working of a DC motor with neat sketch.

Q-2

Draw the circuit diagram of different self excited dc motors also establish various voltage equations of each motor.

Q-3

Derive the torque equation of a dc motor with usual notations?

Q-4

Discuss three important characteristics of DC shunt motor series motor and compound motor?

Q-5

Explain any one speed control method of DC shunt or series motors?

Q-6

With neat sketch explain 3-point starter and 4- point starter?

Q-7

How can you determine the efficiency of DC motor by using brake test method?

## Chapter-3

### Single phase Transformer

#### 3.1- Introduction, definition and working principle:-

##### Definition:-

It is defined as a static electrical device which transfer electrical energy or power from one circuit to another circuit through a magnetic medium with same frequency.

##### Principle:-

It works under the principle of mutual induction.

##### Working:-

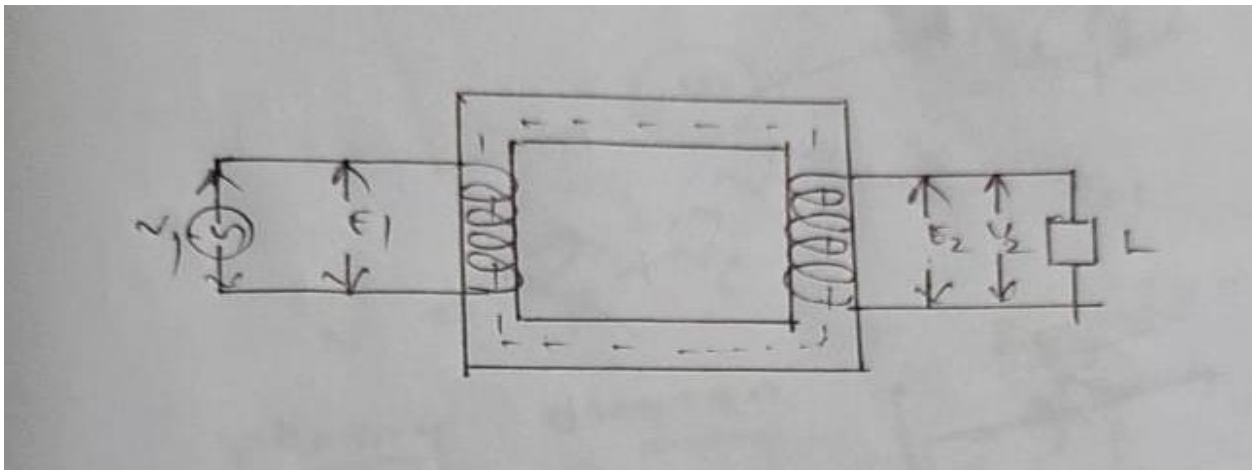

In a transformer basically there are two windings which are wound in a common magnetic core. The winding which is connected to the supply is known as primary winding from which the power is taken is known as secondary winding i.e. load is connected in this secondary winding.

When single phase AC supply is given to the primary winding a current is flowing through the winding which produces an alternating flux which links with the primary coil itself and produces an induced EMF ( $E_1$ ) or back EMF. Then the flux passes through the core and links with the secondary winding and induces a voltage ( $E_2$ ). This voltage  $E_2$  is known as mutually induced EMF.

#### 3.2-Constructional details:

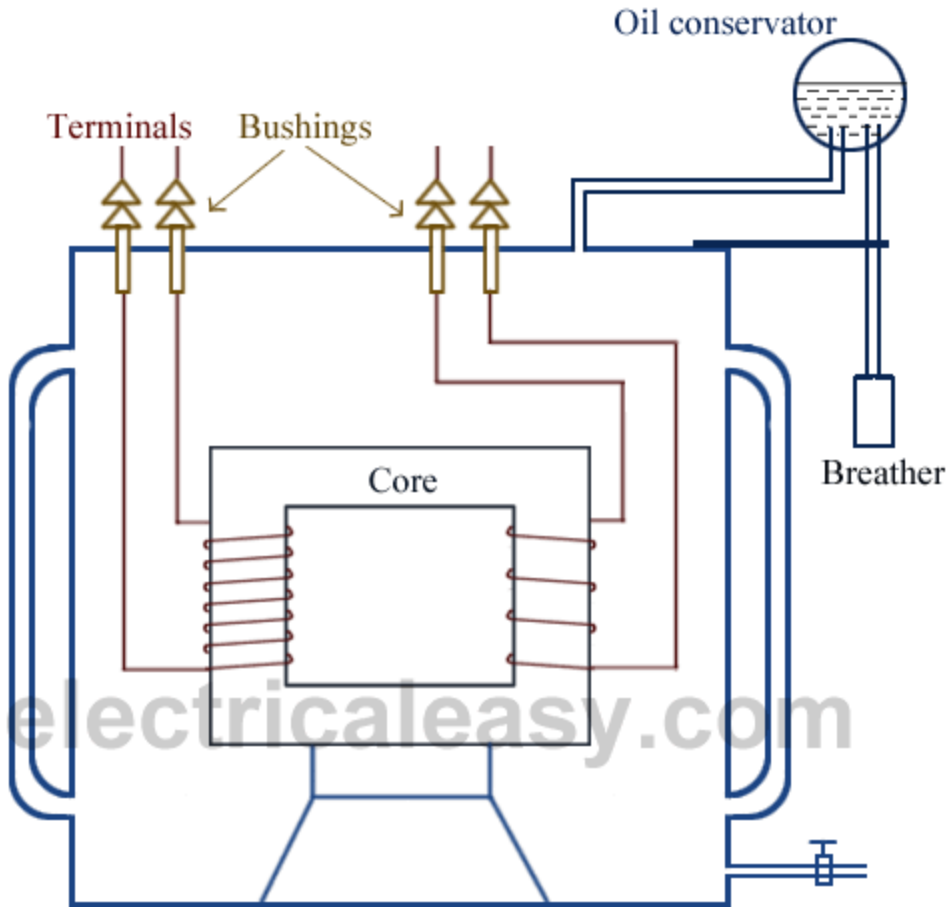

Following are the important parts of a transformer-

- (1) Windings
- (2) Core
- (3) Tank
- (4) Conservator
- (5) Breather
- (6) Bushings

### **3.2.1 Winding and core**

#### **(1) Winding:-**

The winding are made up of copper wire in the form of rectangular or circular shape.

#### **(2)Core:-**

The core is constructed from sheet steel laminations in the form of rectangular shape. The steel is of high silicon content to reduce the hysteresis loss. It is laminated to reduce the eddy current loss.

### **3.2.2 Tank , conservator and breather**

#### **(3)Tank:-**

After winding the transformer is kept inside a tank which is made of sheet steel and is air tight inside the tank some insulating oil is kept so that the core of the transformer is not electrically contact with the tank. The additional function of the oil is to cool the winding.

#### **(4)Conservator:-**

In the top of the tank there is a small cylindrical tank known as conservator. when the transformer oil heat it expand so for expansion of the oil the conservator is required.

#### **(5)Breather:-**

For expansion and contraction or compression of oil in the conservator a breather is kept on the top of the conservator. In the breather some silica gel are kept to observe moisture and dust from the atmosphere and allow pure air into the tank.

#### **(6)Bushings:-**

The transformer winding which are kept inside the tank are brought out of the tank through the bushings. These bushings are either porcelain or oil field or capacitor type.

### **3.2.3-Types of transformers:-**

The transformer can be divided into various types various types in various ways.

(1) **According to construction** -It is divided in two types

(a) Core type transformer

(b) Shell type transformer

#### **Core type transformer:-**

If in a transformer cores are surrounded by the winding then it is called as core type transformer .

**Example-** In generating stations, grids and distribution purposes.

#### **Shell type transformer:-**

If in a transformer windings are surrounded by the cores then it called as shell type transformer.

**Example-**Stabilizers and application in all electronic circuits.

**(2) According to voltage** – The transformer is divided into two types

- (a) Step up transformer
- (b) Step down transformer

**Step up transformer:** -It is defined as a transformer which makes low voltage into high voltage.

Condition-

$$E_2 > E_1$$

$$N_2 > N_1$$

**Application:-**It is used in generating stations and transmission lines.

**Step down transformer:**-It is defined as a transformer which makes high voltage into low voltage.

Condition-

$$E_1 > E_2$$

$$N_1 > N_2$$

**Application:-**

It is used in secondary transmission and distribution purposes.

**Explain types of cooling methods:-**

Following important method are used to cool the transformer-

**For dry type transformer:-**

**(a) Air Natural (AN) cooling method:-**

Generally heat produced in the windings has to be radiated to the air in this method natural air cool the transformer.

**(b) Air Forced (AF) Cooling method:-**

In this method air is forced into the transformer by using blower's.

- This method is used for high rating transformer.

**For oil immersed Transformer:-**

**(a) Oil Natural Air Natural (ONAN):-**

- This method the winding is must in the oil and cooling fans are used for circulation of oil.

- In this method due to maximum heat, the transformer oil is expanded and flows through the cooling tubes.
- These tubes are always in contact with natural air, so the heat is radiated very quickly by this method.

### **(b) Oil Natural Air force (ONAF):-**

In this method in addition to the cooling tubes, extra fans are used which force the air to strike the cooling tubes by this way the heat is radiated very quickly.

### **(c) Oil forced Air forced (OFAF):-**

In this method a pump is connected between the tank and heat exchanger. This pump forces the oil to circulate through the pipe of the exchanger at the same time using fans air is forced on the tubes on which cooling is possible very quickly. This system is used in high rating machines.

### **(d) Oil Natural water forced (ONWF):-**

In this method transformer oil naturally flows through the tubes. This time water is forced on these tubes such that no water goes into the tank.

### **(e) Air Forced water Forced (AFWF):-**

In this method using circulating pumps, the transformer oil is circulated through the cooling tubes in the heat exchanger and at the same time water is forced to spread the heat exchanger.

## **3.3- State the procedure for care and maintenance:-**

To increase durability (life span) of a transformer, periodical maintenance is highly essential. The following are the few important schedules of a single-phase Transformers –

- (1) To check and verify the insulating quality or grade of the transformer oil and accordingly replace it.
- (2) Check whether conductors are tightly connected with the bushings or not.
- (3) Check the signals of Buchholz's relay in a regular interval to know anything goes wrong inside the transformer tank for which gases are formed accordingly precautionary steps must be taken.
- (4) Check and verify the colour of dry silica gel whether changing or not. If changing then pour the new dry silica gel.
- (5) Check three pipe earthing's are properly installed.
- (6) Periodically check the earth resistance of the earthing's for safety purposes.
- (7) In a regular interval measure the insulation resistance of the transformer winding.

## **3.4-Derivation of EMF equation:-**

Let,

$V_1$ =supply voltage to the primary, V

$V_2$ =secondary terminal voltage, V

$N$ =No. of turns in the winding.

$N_1$ =No. of turns in the primary windings.

$N_2$ = No. of turns in the secondary windings.

$E_1$ =Primary induced e.m.f V

$E_2$ =secondary induced e.m.f, V

$F$ = frequency of the supply voltage, Hz

$(\phi)_m$ =Maximum flux in the core, W

When a voltage  $V_1$  is applied to the primary a flux  $(\phi)_m$  is produced. whose nature is alternating (sinusoidal) as in figure.

The flux will be maximum after  $T/4$  sec i.e  $1/(4f)$  sec.

The change in flux to achieve maximum flux i.e  $d\phi = \phi_m$

The change in time  $dt = 1/4f$

According Faraday's laws of electromagnetic induction, the average induced e.m.f for  $N$  no. of turns is given by,

$$e = N (d\phi/dt)$$

$$= N \times \phi_m / (1/4f)$$

$$e = 4f \phi_m N$$

### R.M.S value of e.m.f,

$$E_{rms} = \text{Form factor} \times \text{Avg e.m.f}$$

$$= K f \times e$$

$$E = 1.11 \times 4f \phi_m N$$

$$\Rightarrow E = 4.44f \phi_m N, V$$

Now  $E_1 = 4.44f \phi_m N_1, V$  ( for primary)

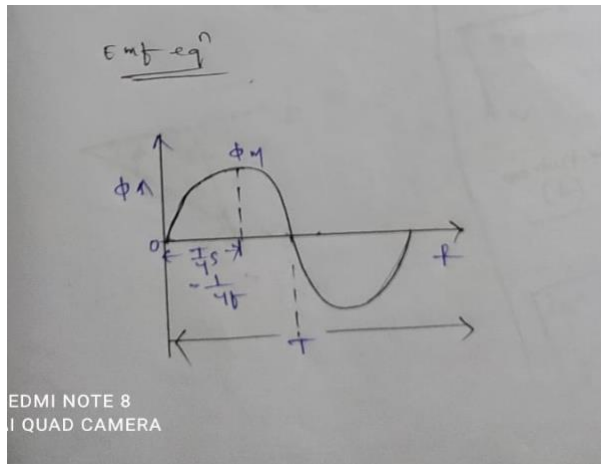

&  $E_2 = 4.44f \phi_m N_2$ , V (for secondary)

### 3.5-Voltage transformation ratio of an ideal T/F .

#### Transformation Ratio:-

Let,

$E_1$  = primary induced e.m.f , V

$E_2$  = secondary induced e.m.f , V

$V_1$  = primary supplied voltage, V

$V_2$  = secondary load voltage, V

$I_1$  = primary current, A

$I_2$  = Secondary current, A

$N_1$  = primary no. of turns.

$N_2$  = Secondary no. of turns.

K = Transformation Ratio.

From e.m.f equation we know that

$E_1 \propto N_1$

$E_2 \propto N_2$

$$\Rightarrow E_2/E_1 = N_2/N_1 \text{-----(1)}$$

In an Idea transformer,

$E_1 = V_1$

&  $E_2 = V_2$

$$\Rightarrow E_2/E_1 = V_2/V_1 \text{-----(2)}$$

Again in an ideal transformer losses are neglected .

Hence input power = Out put power

$V_1 I_1 = V_2 I_2$

$$\Rightarrow V_2/V_1 = I_1/I_2 \text{-----(3)}$$

Comparing equation (1),(2)&(3) we get,

$$E_2/E_1 = V_2/V_1 = N_2/N_1 = I_1/I_2 = K$$

### 3.5-Explanation of an Ideal T/F on no load with phaser diagram:-

#### Definition:-

The transformer which has no copper loss, no iron loss ,no winding resistance ,No magnetic leakage is known as ideal transformer.

- There is practically no ideal transformer.

#### Explanation:-

#### When the transformer on No load:-

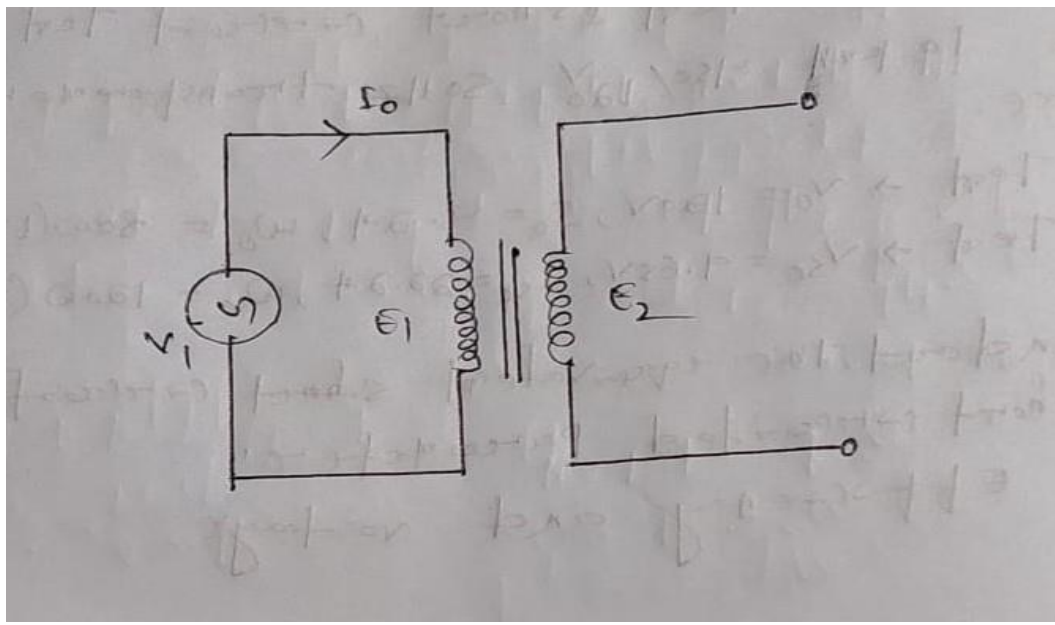

When a transformer is loaded there is some iron loss and copper loss. when the transformer is on no load the primary current is not  $90^\circ$  lagging behind the supply voltage but makes an angle less than  $90^\circ$  and taking flux as reference vector,

Let it be  $(\phi)_0$

i.e  $\phi_0 < 90^\circ$

Where  $I_0$  is the no load current in the primary.

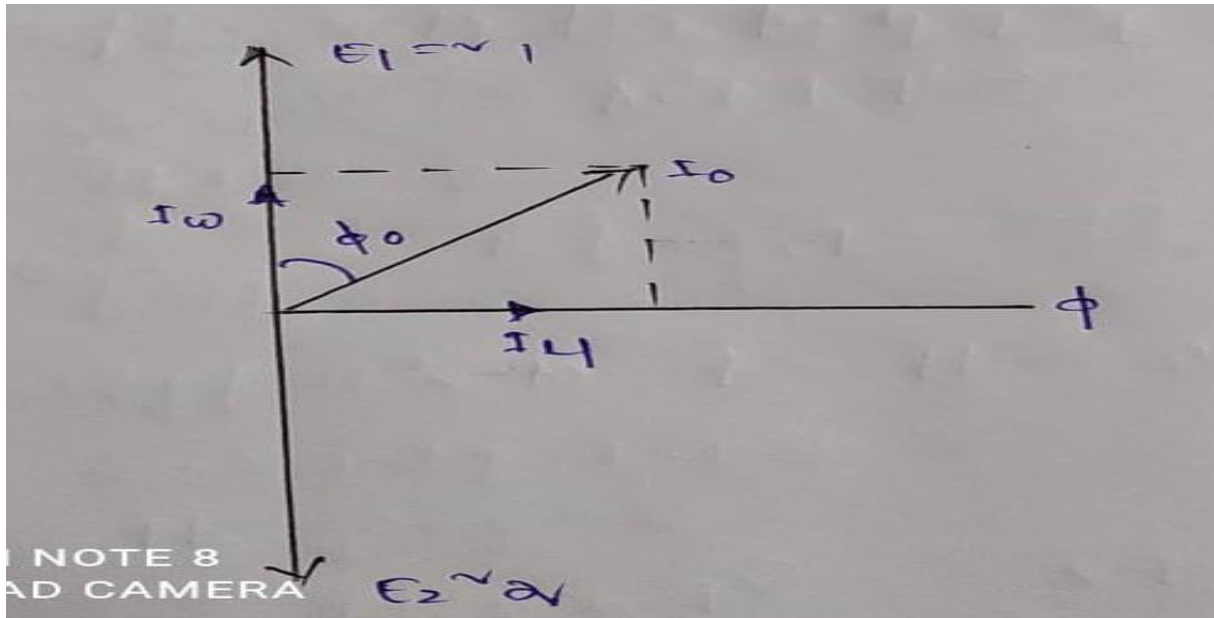

- The current ( $I_0$ ) can be resolved into two components such as magnetising component and wattfull component or iron loss component.

### Magnetising component ( $I_\mu$ ):-

The resolved component of no load current along the Flux-axis is called magnetising component or magnetising current.

$$I_\mu = I_0 \sin \phi_0$$

### Wattfull or iron loss component ( $I_w$ ):-

The resolved component of no load current along primary voltage axis is called wattfull or iron loss components.

$$I_w = I_0 \cos \phi_0$$

Hence  $\vec{I}_0 = \vec{I}_\mu + \vec{I}_w$

### The power input to the transformer at no load:-

Let

$V_1$  = Primary voltage

$V_2$  = secondary voltage

$E_1$  = Primary induced e.m.f

$E_2$ =secondary induced e.m.f

$I_0$ =No load current on primary side

$R_1$ =primary winding resistance

$R_2$ =Secondary winding resistance

$\cos \phi_0$  = No load power factor

We know that

Input power= output power + total losses

$$P_i = P_o + W_t$$

$$= 0 + \text{Iron loss} + \text{Total copper loss}$$

$$= W_o + \text{primary Cu. Loss} + \text{Secondary Cu. Loss.}$$

$$= W_o + I_0^2 R_1 + 0$$

$$= W_o + I_0^2 R_1$$

As no load current is very small so the no load primary Cu. Loss ( $I_0^2 R_1$ ) is very very small, Hence it can be neglected. The primary input to the transformer is practically the iron loss in the transformer.

$$P_i = W_o = V I_0 \cos \phi_0, W$$

#### Problem-1

A single phase transformer has 400 primary and secondary turns. The net cross-sectional area of the core is  $60 \text{ cm}^2$ . If the primary winding is connected to a 50 Hz supply at 520V then calculate,

- i. Peak value flux density
- ii. The voltage induced in the secondary winding.

Data given

$$N_1 = 400$$

$$N_2 = 1000$$

$$A = 60 \text{ CM}^2$$

$$f = 50 \text{ Hz}$$

$$V_1 = 520 \text{ V}$$

Required data =  $B_M = ?$

$E_2 = ?$

Solution

i. If it is an ideal transformer  $V_1 = E_1 = 520 \text{ v}$

We know that

$$E_1 = 4.44 f \phi_m N_1 \quad \left[ B_M = \frac{\phi_M}{A}, \quad \frac{W_b}{m^2} \right] \quad [\phi_m = B_m A]$$

$$E_1 = 4.44 f B_m A N_1$$

$$\begin{aligned} \Rightarrow B_m &= \frac{E_1}{4.44 f A N_1} \\ &= \frac{520}{4.44 \times 50 \times 60 \times 10^{-4} \times 4000} \\ &= 0.97 \text{ Wb/m}^2 \end{aligned}$$

ii.  $K = N_2/N_1$   
 $= 1000/4000 = 2.55$   
 $E_2 = K \times E_1 = 2.5 \times 520 = 1300$

Problem -2

A 25 KvA transformer has 500 turns on the primary and so turns on the secondary the primary is connected to 3000 v at 50 hz frequency find the full load primary secondary currents. The secondary emf and the maximum flux in the core.

Data given

$$P = 25 \text{ KvA} = 25 \times 10^3 \text{ VA}$$

$$N_1 = 500$$

$$N_2 = 50$$

$$V_1 = E_1 = 3000 \text{ V}$$

$$f = 50 \text{ hz}$$

required data

$$I_1 = ?$$

$$I_2 = ?$$

$$\Phi_M = ?$$

$$E_2 = ?$$

Sol<sup>n</sup>

Let it be a ideal transformer  $V_1 I_1 = V_2 I_2 = 25 \times 1000 \text{ KvA}$

Let  $I_1$  Rated full load current in the primary

$I_2$  is the rated full load current in the secondary

$$V_1 I_1 = 25 \times 10^3$$

$$I_1 = \frac{25 \times 10^3}{V_1}$$
$$= \frac{25 \times 10^3}{3000} = 8.3 \text{ A}$$

$$K = N_2 / N_1$$

$$= 50 / 500$$

$$= 0.1$$

$$\frac{I_1}{I_2} = K$$

$$\Rightarrow I_2 = \frac{I_1}{K} = \frac{8.3}{0.1} = 83 \text{ A}$$

$$\Rightarrow E_1 = 4.44 f \phi_m N_1$$

$$= \phi_m = \frac{3000}{4.44 \times 50 \times 500} = 0.027 \text{ Wb}$$

$$E_2 / E_1 = K$$

$$\Rightarrow E_2 = K E_1 = 0.1 \times 3000$$
$$= 300 \text{ V}$$

Problem-3

The number of turns on the primary and secondary winding of a 1- $\phi$  transformer are 350 and 35 respectively. If the primary is connected to a 2.2 kv ,50 hz supply . determine the secondary voltage on no load.

Data given

1-phase transformer

$$N_1 = 350$$

$$N_2 = 35$$

$$V_1 = 2.2 \text{ KV}$$

$$= 2.2 \times 10^3 \text{ V}$$

$$f = 50 \text{ Hz}$$

required data

$$E_2 = ?$$

Solution

Let it be an ideal transformer

$$\text{Here } V_1 = E_1 = 2200 \text{ V}$$

We know that

$$\begin{aligned} \frac{E_2}{E_1} &= \frac{N_2}{N_1} \\ \Rightarrow E_2 &= \frac{N_2}{N_1} \times E_1 \\ &= \frac{2200 \times 35}{350} \\ &= 220 \text{ V} \end{aligned}$$

Problem-4

2200/200 v transformer draws a no load primary current of 6A and observes 400 watt  
find the magnetising and iron loss current

Data given

$$E_1 = V_1 = 2200 \text{ V}$$

$$E_2 = V_2 = 200 \text{ V}$$

$$I_0 = 0.6 \text{ A}$$

$$W_0 = 400 \text{ Watts}$$

Required data

$$I_\mu = ?$$

$$I_w = ?$$

Ans

We know that

$$W_0 = V_1 I_1 \cos \phi_0$$

$$\cos \phi_0 = 0.30$$

$$\sin \phi_0 = \sqrt{1 - \cos^2 \phi_0}$$

$$= \sqrt{1 - 0.3^2}$$

$$= \sqrt{1 - 0.09}$$

$$= \sqrt{0.91}$$

$$= 0.95$$

$$\sin \phi_0 = 0.95$$

$$I_{\mu} = I_0 \sin \phi_0$$

$$= 0.6 \times 0.95$$

$$= 0.57 \text{ A}$$

$$I_w = I_0 \cos \phi_0$$

$$= 0.6 \times 0.30$$

$$= 0.18 \text{ A}$$

#### Problem-5

A 2200 / 250 transformer draws current of 0.5 A at a power factor of 0.3 on open circuit find the magnetising component and the working component of the load current.

Data given

$$V_1 = 2200 \text{ V}$$

$$V_2 = 250 \text{ V}$$

$$I_0 = 0.5 \text{ A}$$

$$\cos \phi_0 = 0.3$$

Required data

$$I_{\mu} = ?$$

$$I_w = ?$$

Solution

$$\sin \phi_0 = \sqrt{1 - \cos^2 \phi_0}$$

$$= \sqrt{1 - 0.3^2}$$

$$= \sqrt{1 - 0.09}$$

$$= \sqrt{0.91}$$

$$= 0.95$$

The magnetising component

$$I_{\mu} = I_0 \sin \phi_0$$

$$= 0.5 \times 0.95$$

$$= 0.476 \text{ A}$$

The working component or iron loss current

$$I_w = I_0 \cos \phi_0$$

$$= 0.5 \times 0.3$$

$$= 0.15 \text{ A}$$

### **3.6-phaser diagram of an ideal T/F on load(U PF, Lagging & Leading P.F):-**

When the transformer is loaded a current  $I_2$  is flowing through the secondary winding due to this current a flux is produced in the secondary winding and it opposes the flux due to the primary winding.

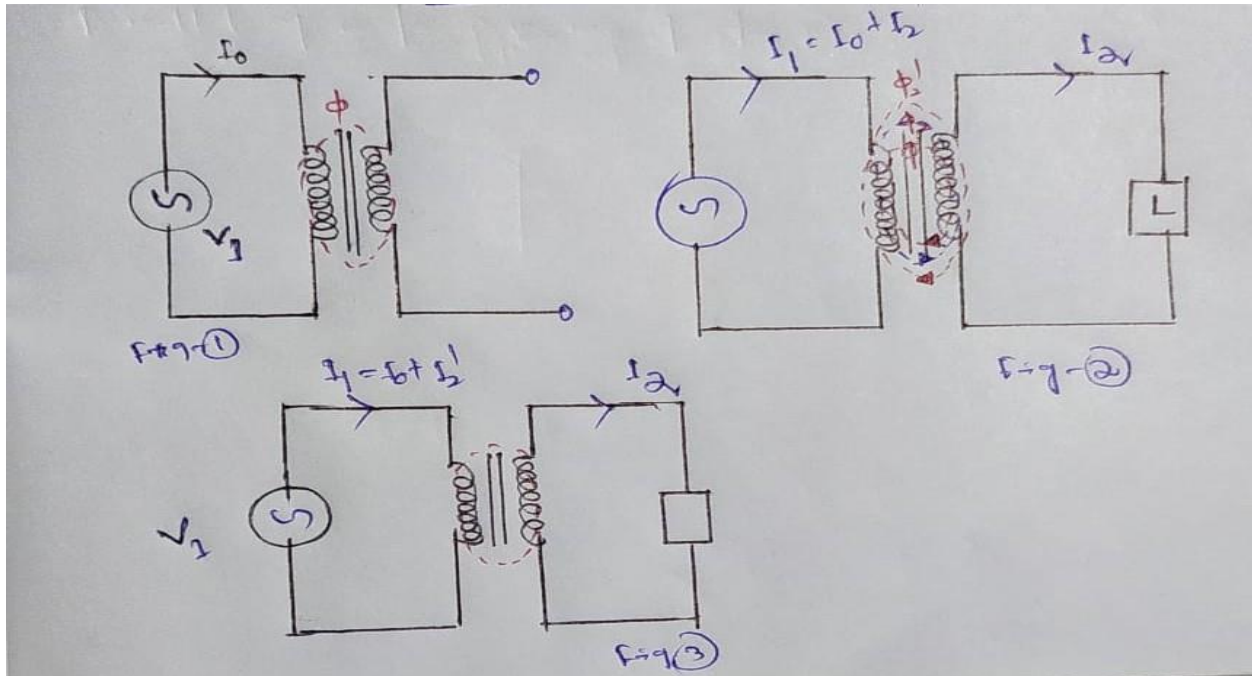

Let this flux is  $\phi_2$

Hence the net flux in the core decreases momentarily and the  $E_1$  decreases. For the time being the potential difference between  $V_1$  &  $E_1$  increases and hence a high amount of current flowing through the primary.

Let  $I_2'$  be the additional current flowing through the primary this current is known as load component of primary. Due to this current an additional flux ( $\phi_2$ ) is produced and which opposes the flux  $\phi_2$  and it is can solve each other and the net flux in the core remains constant.

Hence whatever may be the load the flux remain constant in the core. As the flux remain constant the iron loss or core loss is also constant from no load to full load.

From above discussion.

$$(\phi_2 = \phi_2$$

$$\Rightarrow N_1 I_2' = N_2 I_2$$

$$\Rightarrow I_2' = (N_2/N_1) \times I_2$$

$$\Rightarrow I_2' = K I_2$$

$$\Rightarrow \underline{I_2' = -K I_2}$$

$I_2'$  is opposite to the

Hence we can say the primary current

( $I_1$ ) is sum of (vectorically) no load current ( $I_0$ ) and  $I_2'$  i.e

$$I_1 = I_0 + I_2' \text{ (vector sum)}$$

Where,

$I_1$  = primary current, A

$I_2$  = Secondary current, A

$I_0$  = No load primary current, A

$I_2'$  = Reflected current of secondary on primary side, A

**Phaser diagram:-**

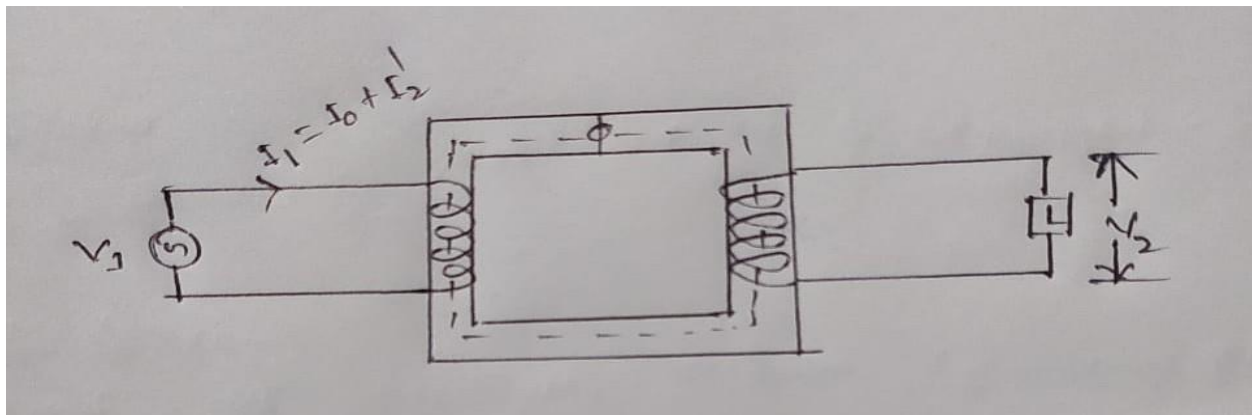

We know that,

$$I_2' = -k I_2$$

In ideal T/F

$$K=1$$

So  $I_2' = -I_2$

Again 
$$\vec{I}_1 = \vec{I}_0 + \vec{I}_2'$$

We will discuss the phaser diagram for resistive load (Unity power factor), Inductive load (Lagging power factor) & Capacitive load (leading power factor).

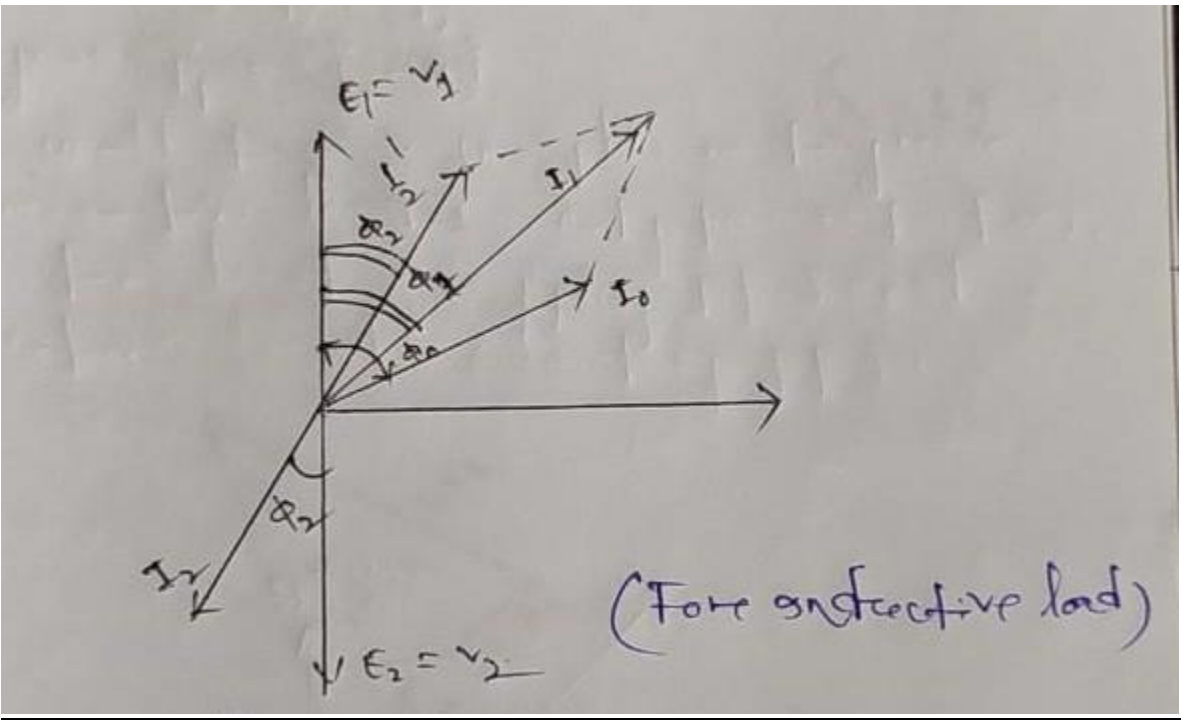
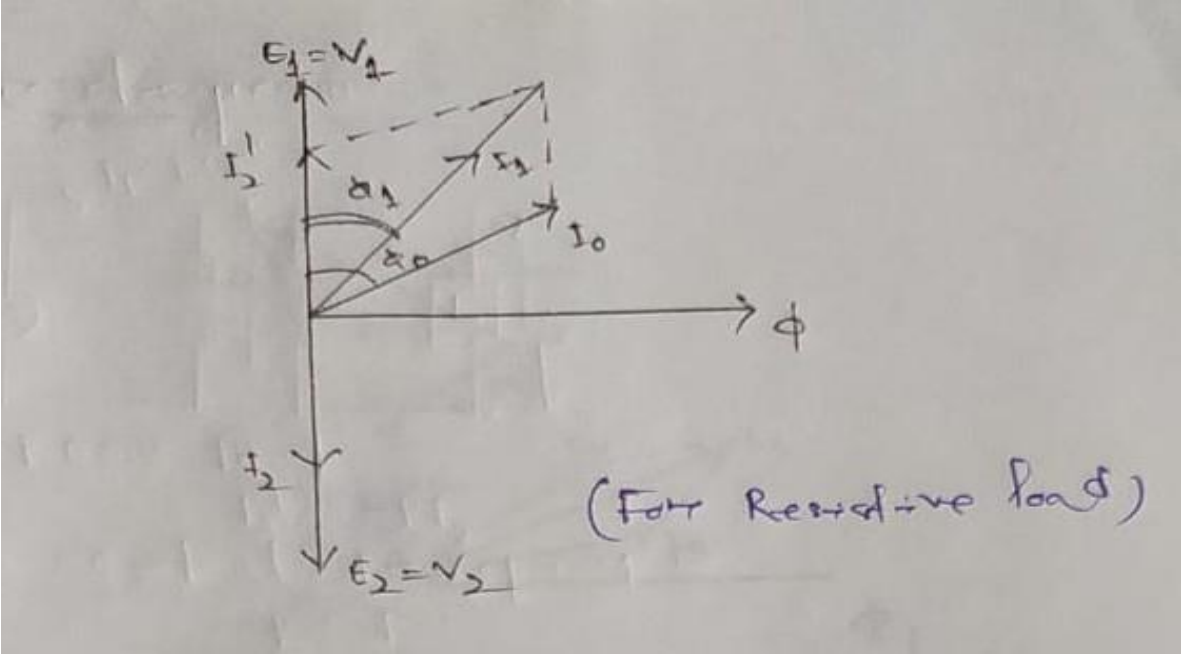

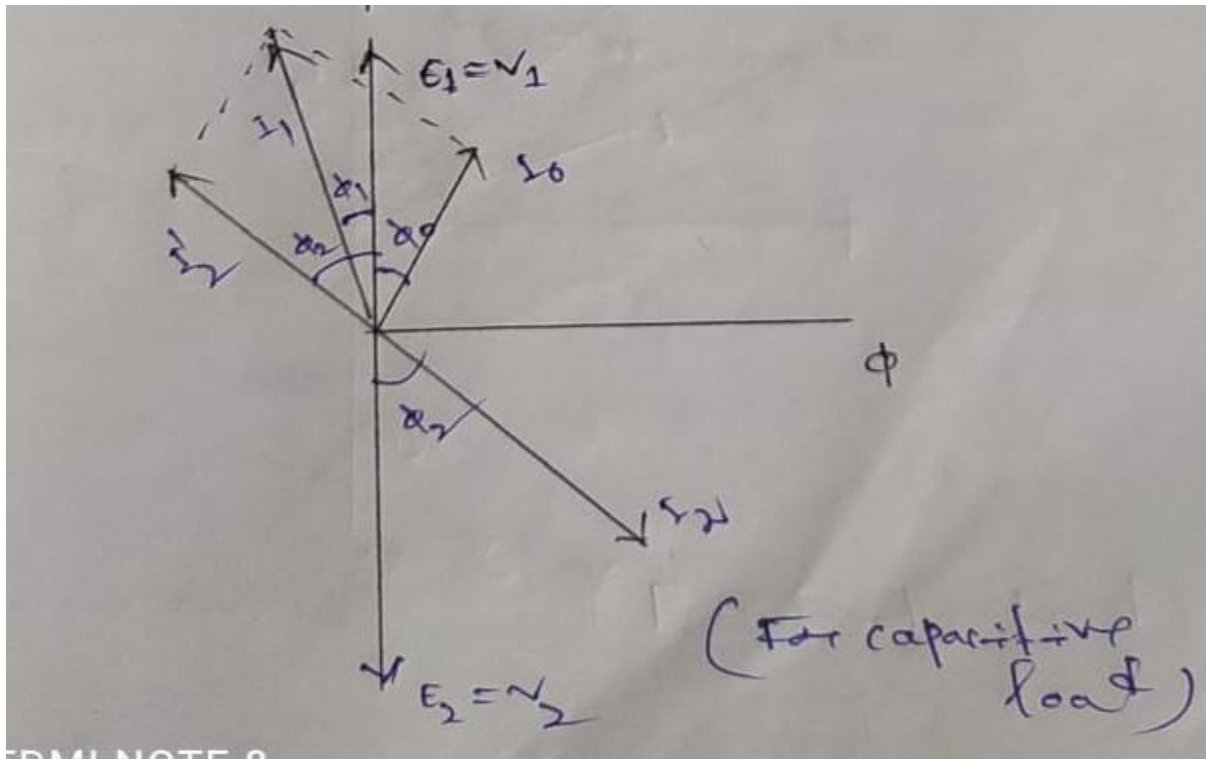

**3.7 Explanation of equivalent resistance, Reactance and Impedance:-**

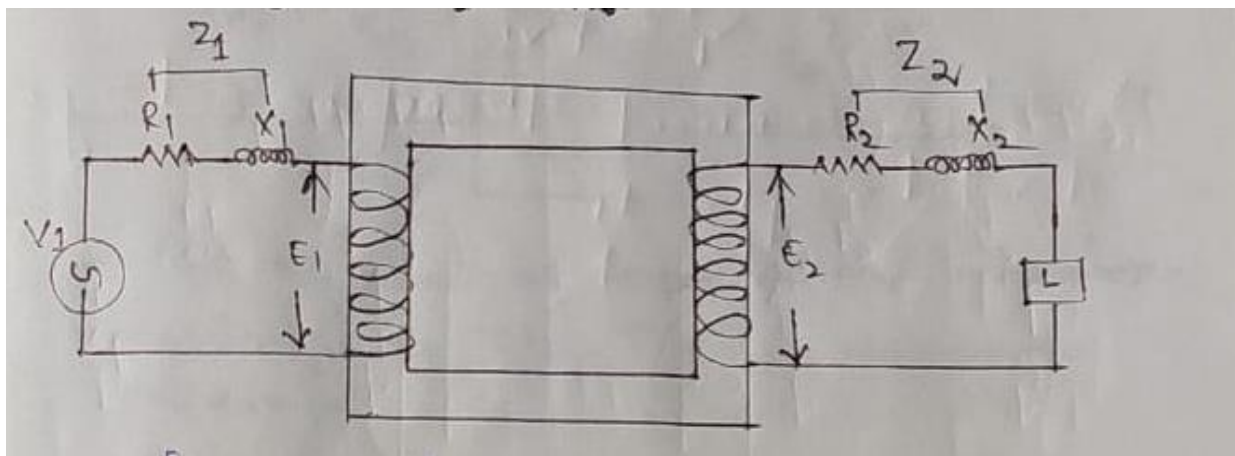

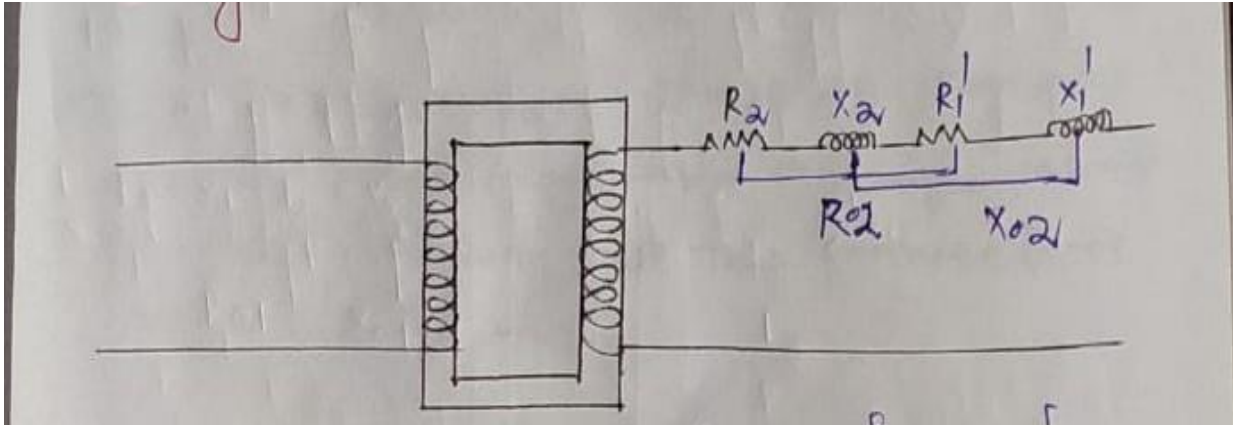

- When secondary resistance, reactance and impedance are shifted to primary that its value in primary side is

$$= \frac{R_2}{K^2}, \frac{X_2}{K^2} \text{ \& \ } \frac{Z_2}{K^2} \text{ respectively}$$

Where we can represent

$$R_2^1 = \frac{R_2}{K^2}, \quad X_2^1 = \frac{X_2}{K^2}, \quad Z_2^1 = \frac{Z_2}{K^2}$$

$R_2^1$  is known as secondary resistance as refer to primary

$X_2^1$  is the secondary reactance as refer to primary

$Z_2^1$  is the secondary impedance as refer to primary

$R_{01}$  → is known as equivalent resistance of the transformer as refer to primary

$X_{01}$  → is known as equivalent reactance of the T/F as refer to primary

$Z_{01}$  → is known as equivalent impedance of the T/F as refer to primary

$$R_{01} = R_1 + R_2^1$$

$$= R_1 + \frac{R_2}{K^2}$$

$$X_{01} = X_1 + X_2^1$$

$$= X_1 + \frac{X_2}{K^2}$$

$$Z_{01} = \sqrt{((R_{01})^2 + (X_{01})^2)}$$

Similarly when secondary voltage as transfer to primary  $K$  is divided for eg →

$$E_2^1 = \frac{E_2}{K} \quad V_2^1 = \frac{V_2}{K}$$

→ When secondary current are transfer to primary  $K$  is multiplied

$$I_2^1 = K I_2$$

## Primary parameter shifted secondary

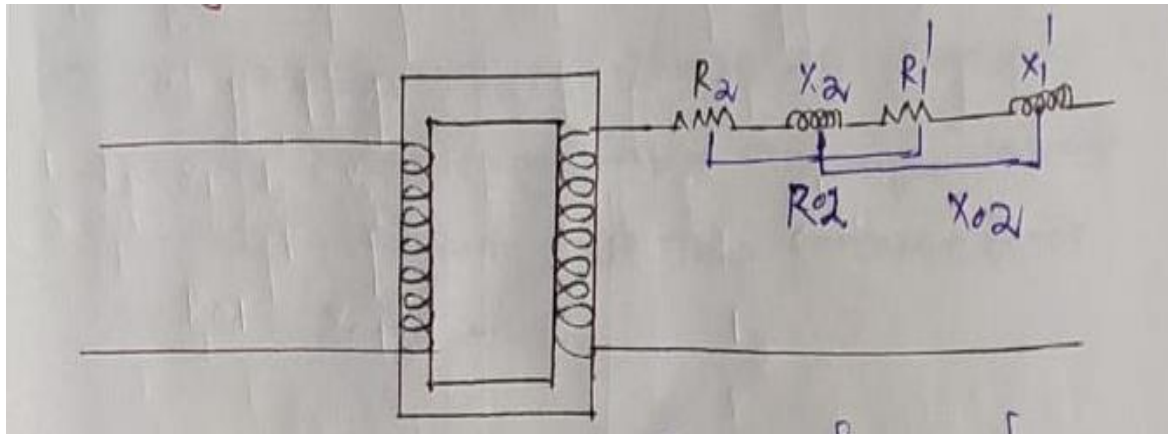

When primary parameter shifted to secondary the  $K^2$  is multiplied and is represented as

$$R_1' = K^2 R_1, \quad X_1' = K^2 X_1, \quad Z_1' = K^2 Z_1$$

Where  $R_1'$  is known primary resistance as refer to secondary

$X_1'$  is known as primary reactance as refer to secondary

$Z_1'$  is known as primary impedance as refer to secondary

$$R_{02} = R_2 + R_1'$$

$$= R_2 + K^2 R_1$$

$$X_{02} = X_2 + X_1'$$

$$= X_2 + K^2 X_1$$

$$Z_{02} = \sqrt{((R_{02})^2 + (X_{02})^2)}$$

$R_{02} \rightarrow$  is the equivalent resistance of the transformer as refer to secondary

$X_{02} \rightarrow$  is the equivalent reactance of the T/F as refer to secondary

$Z_{02} \rightarrow$  is the equivalent impedance of the T/F as refer to secondary

$\rightarrow$  When primary voltage shifted to the secondary  $K$  is multiplied i.e

$$V_1' = K V_1$$

$\rightarrow$  When current transfer secondary is divided i.e

$$I_1' = \frac{I_1}{K}$$

### 3.8 Phasor diagram of practical transformer with winding resistance & magnetic leakage for UPF lagging & leading PF

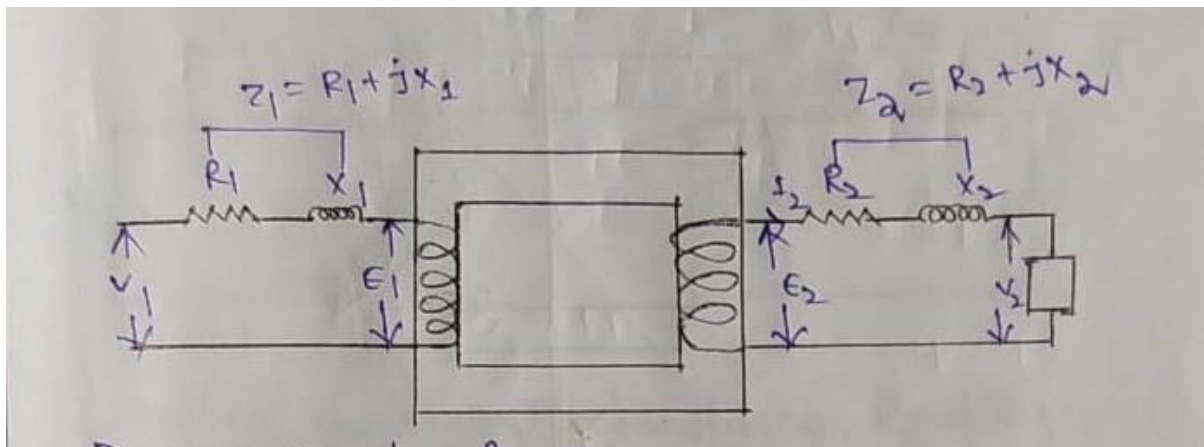

Primary side equation →

$$\begin{aligned} \vec{V}_1 &= -\vec{E}_1 + I_1 R_1 + j I_1 X_1 \\ &= -\vec{E}_1 + I_1 (R_1 + j X_1) \\ &= -\vec{E}_1 + I_1 Z_1 \end{aligned}$$

Where  $Z_1 = R_1 + j X_1$

$$|Z_1| = \sqrt{(R_1)^2 + (X_1)^2}$$

Similarly the voltage equation in secondary side

$$\begin{aligned} \vec{V}_2 &= \vec{E}_2 - I_2 R_2 - j I_2 X_2 \\ &= -I_2 (R_2 + j X_2) \\ &= -\vec{E}_2 - I_2 Z_2 \end{aligned}$$

Where  $Z_2 = R_2 + j X_2$

$$|Z_2| = \sqrt{(R_2)^2 + (X_2)^2}$$





### 3.9 Equivalent circuit of transformer :-

The transformer shown in figure can be resolved into an equivalent circuit giving all the parameter as shown in figure.

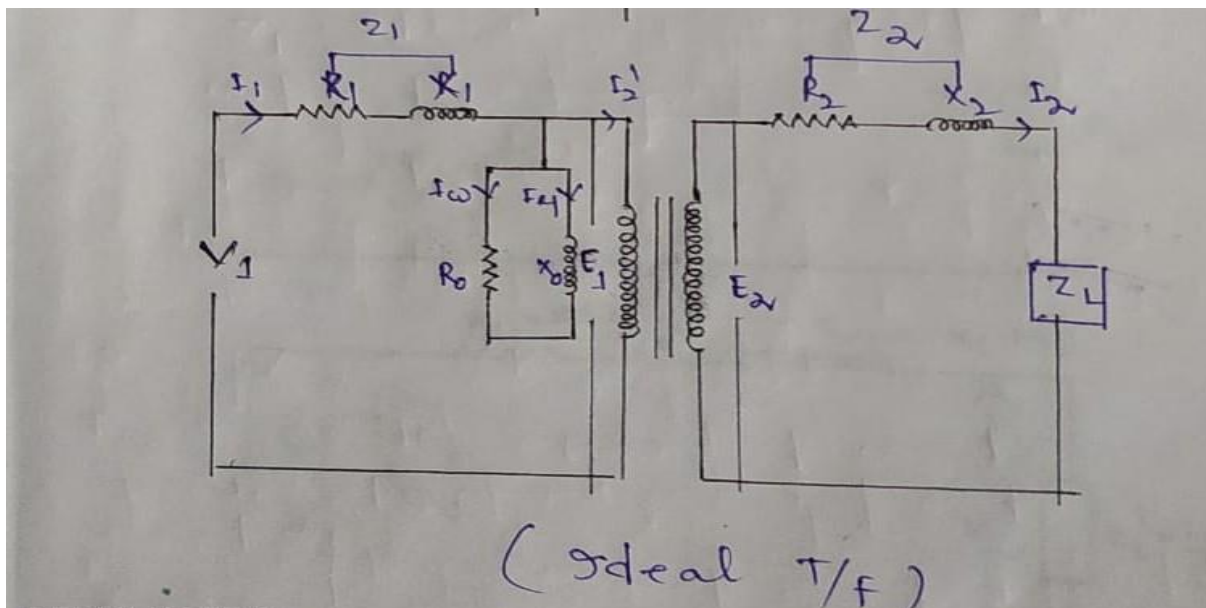
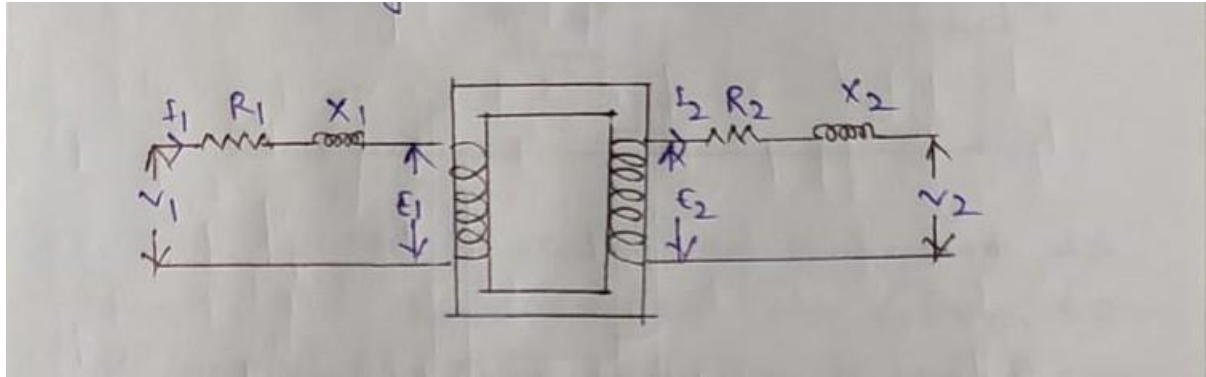

→ Now we can transfer the secondary parameter to the primary side

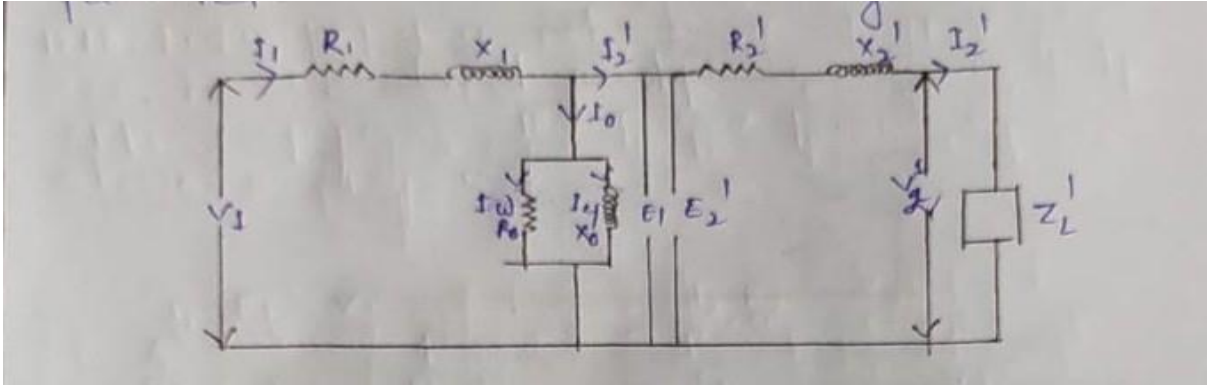

→ The above equivalent diagram is some what harder circuit to solve so to simplify the exciting circuit can be moved to the beginning. So the circuit diagram is as below.

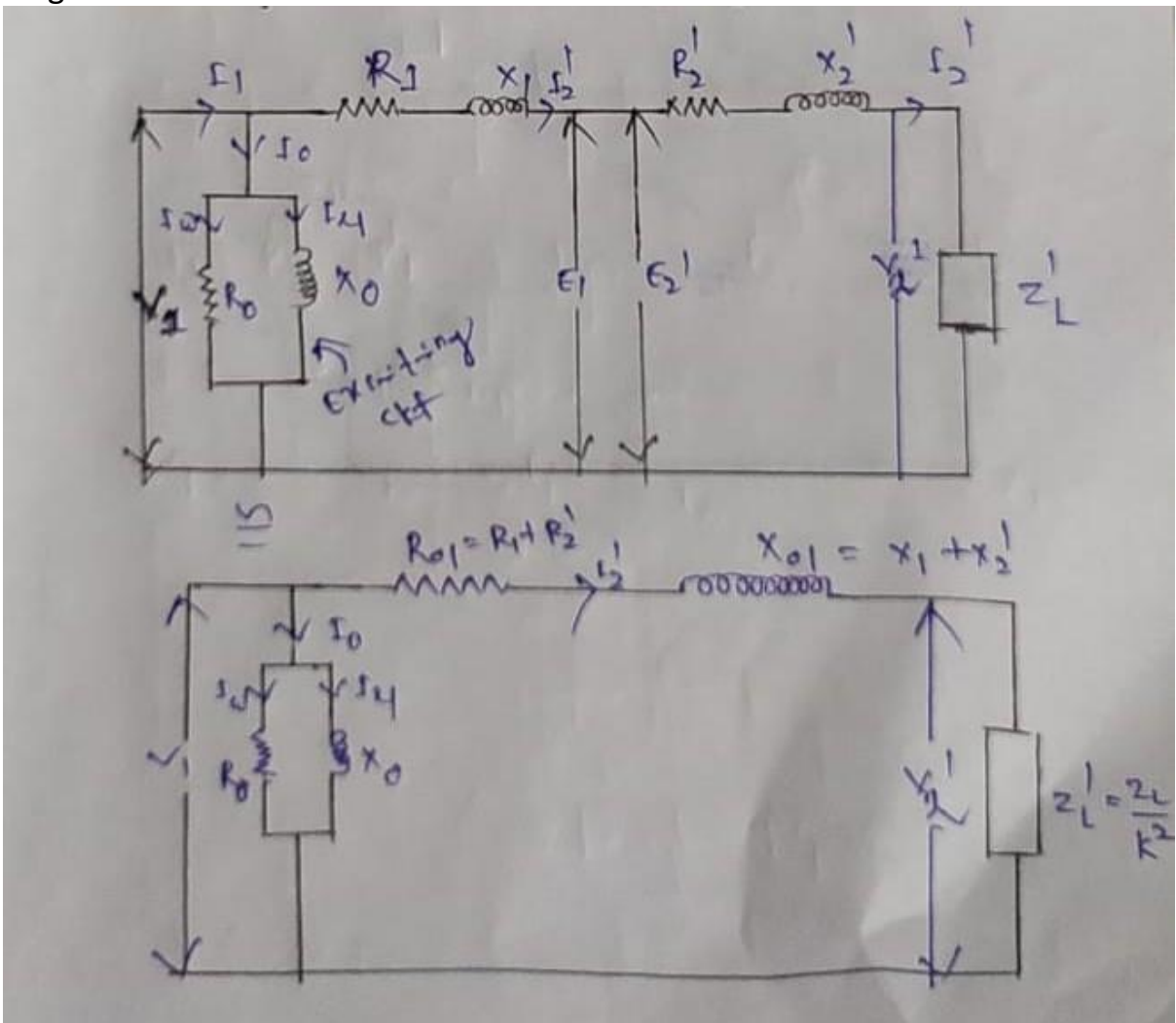

For further simplification we can neglect the exciting parameter.

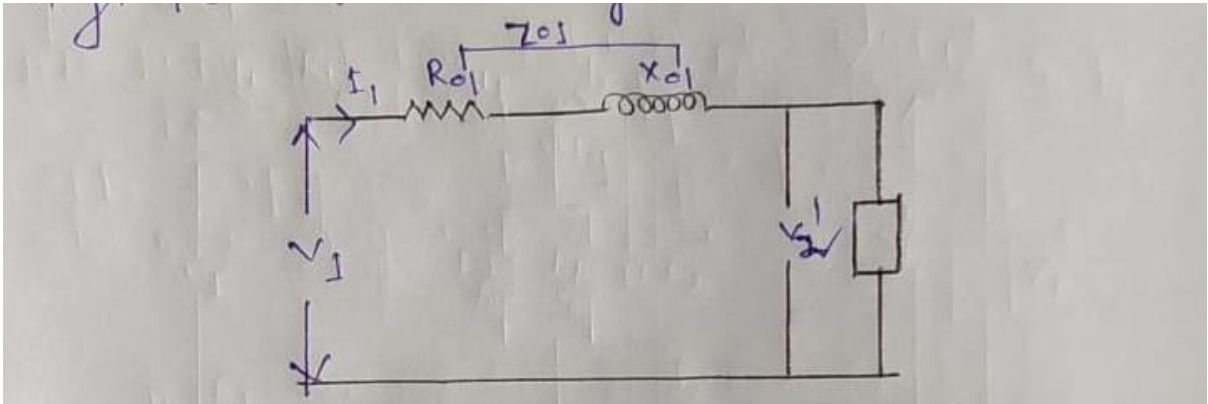

(simplified equivalent circuit of a transformer as refer to primary)

Similarly equivalent circuit diagram as refer secondary :-

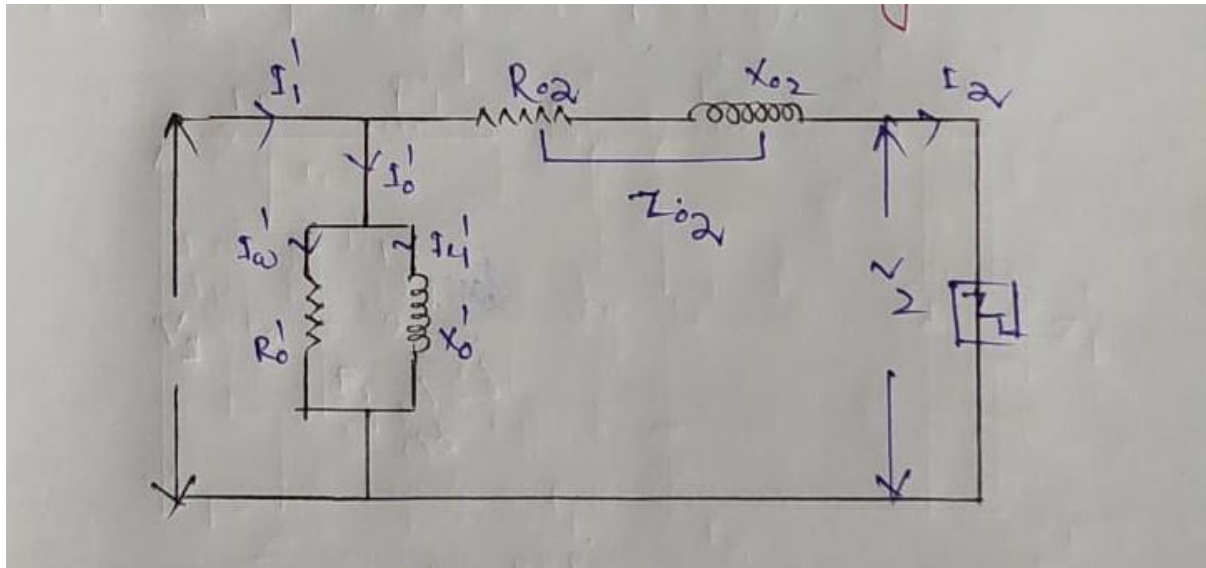

**3.10 Derivation of approximate & exact voltage drop of a transformer:-**

Approximate voltage drop in a single phase transformer

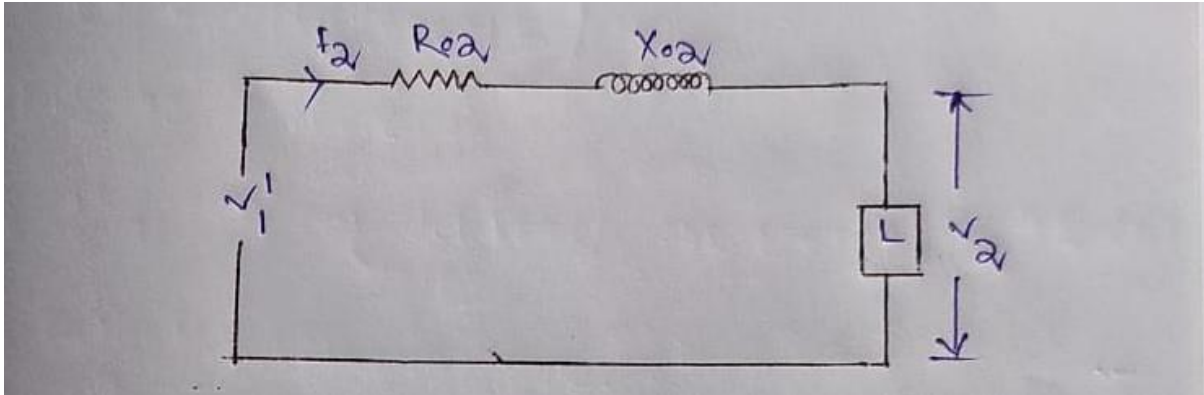

From the above diagram we have

$$V_1 - (I_2 R_{02} + j I_2 X_{02}) = V_2$$

$$\Rightarrow V_1 = V_2 + (I_2 R_{02} + j I_2 X_{02}) \text{-----(1)}$$

$$\Rightarrow V_1 - V_2 = I_2 R_{02} + j I_2 X_{02}$$

$$\Rightarrow \text{Drop} = I_2 R_{02} + j I_2 X_{02}$$

### Vector diagram

Taking  $V_2$  as reference vector, the vector diagram of  $V_1$  for lagging power factor is drawn below.

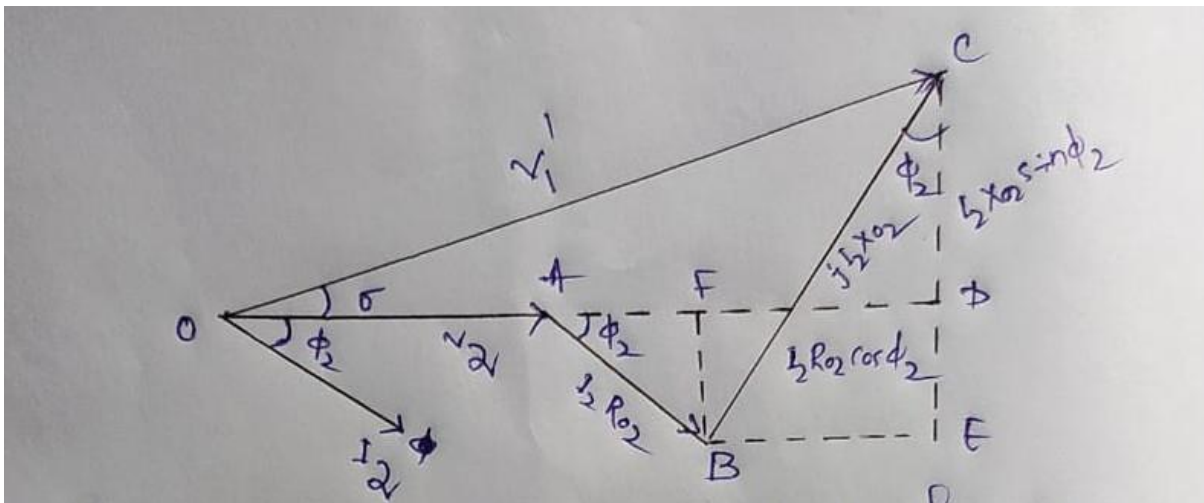

To minimise the drop the angle  $\phi$  should be reduced to zero (0)

$$\text{Hence drop} = V_1 - V_2$$

$$= OD - OA$$

$$= AD$$

$$=AF+FD$$

$$=I_2 R_{02} \cos \phi_2 + I_2 X_{02} \sin \phi_2$$

Approximate voltage drop

$$=I_2 R_{02} \cos \phi_2 + I_2 X_{02} \sin \phi_2$$

+ve sign for lagging power factor

-ve sign for leading power factor

### 3.11 Calculation of voltage Regulation at different power factor:-

#### Voltage regulation:

Voltage regulation of a transformer is the arithmetic difference between the no load secondary voltage ( $ov_2$  or  $E_2$ ) and secondary voltage of no load and expressed as percentage of no load voltage.

$$\% VR = \frac{OV_2 - V_2}{OV_2} \times 100$$

Voltage regulation are two types-

i.  $\% VR \text{ (down)} = \frac{OV_2 - V_2}{OV_2} \times 100$

ii.  $\% VR \text{ (up)} = \frac{OV_2 - V_2}{V_2} \times 100$

$OV_2 - V_2$  is the drop of the transformer so we can write ,

$$\%VR = \frac{I_2 R_{02} \cos \phi_2 \pm I_2 X_{02} \sin \phi_2}{OV_2} \times 100$$

$$= \frac{I_2 R_{02}}{OV_2} \times 100 \cos \phi_2 \pm \frac{I_2 X_{02}}{OV_2} \times 100 \sin \phi_2$$

$$= V_R \cos \phi_2 \pm V_X \sin \phi_2$$

Where  $V_R$  is the percentage resistive drop  $= \frac{I_2 R_{02}}{OV_2} \times 100$

$V_R$  is also known as % R

( $V_R = \% R$ )

Similarly  $V_X$  is the percentage of reactance drop  $= \frac{I_2 X_{02}}{OV_2} \times 100$

Percentage of impedance ,

$$\% Z = \sqrt{(\%R)^2 + (\%X)^2}$$

$$\% Z = \frac{I_2 Z_{02}}{OV_2} \times 100$$

As refer to primary

$$\% R = VR = \frac{I_1 R_{01} \cos \phi_1 \pm I_1 X_{01} \sin \phi_1}{V_1}$$

$$V_R = \frac{I_1 R_{01}}{V_1} \times 100, \quad V_X = \frac{I_1 X_{01}}{V_1} \times 100$$

$$\% Z = \frac{I_1 \mu_1}{V_1}$$

**The vector diagram for different power factors are as follows:-**

unity power factor.

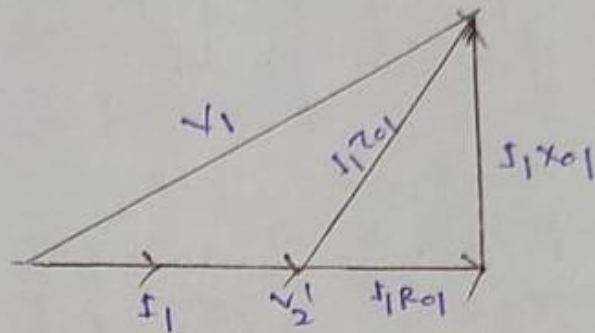

Lagging power factor :-

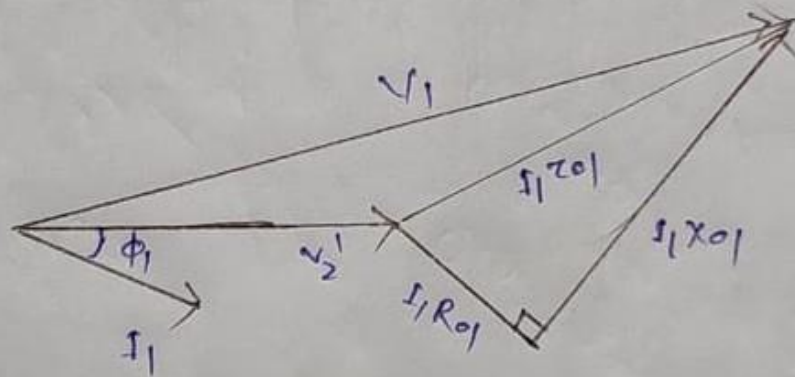

Leading power factor

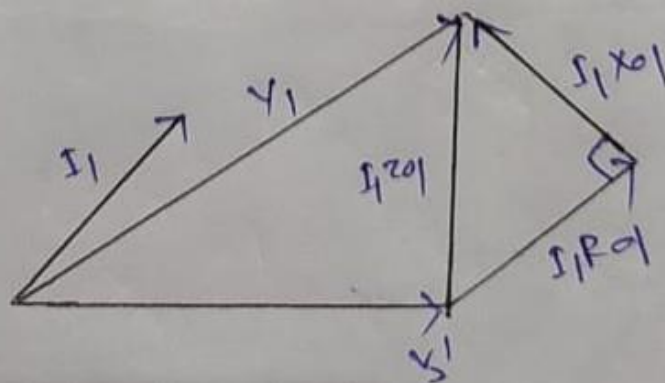

### 3.12 losses and efficiency of 1- $\phi$ transformer

#### Losses in a transformer

Loss are two types of 1- $\phi$  transformer

- i. Iron loss
- ii. Copper loss
- i. Iron loss  
Iron loss are in 2 types
  - a) Eddy current loss
  - b) Hysteresis loss
- a. Eddy current loss:

$$W_e = \eta_e B^2 f^2 t^2 v \text{ , watt}$$

- b. Hysteresis loss:

$$W_h = \eta_h B_{\max}^{1.2} f v \text{ , watt}$$

Where  $t \rightarrow$  thickness of the lamination

$v \rightarrow$  volume of the magnetic

$B_{\max} \rightarrow$  maximum flux density

Iron loss is known as constant loss because as the flux in the core is constant from no load to full load. Iron loss can be find from the no load test i.e o.c test.

#### Copper loss:

In transformer iron loss occurs in primary and in the secondary winding.

Hence copper loss  $W_c = I_1^2 R_1 + I_2^2 R_2$

$I_1^2 R_1 =$  Primary winding copper loss

$I_2^2 R_2 =$  secondary copper loss

$\rightarrow$  The copper loss can be find out from sc test.

#### Efficiency of 1- $\phi$ transformer

$$\eta = \frac{\text{output}}{\text{input}} \times 100$$

$$\eta = \frac{\frac{o}{p} \text{ in watt}}{\frac{i}{p} \text{ in watt}} \times 100$$

$$\eta = \frac{o/p}{o/p + \text{losses}} \times 100$$

### **output KvA corresponding to maximum efficiency:**

let  $W_c$  is the full load copper loss.

$W_i$  is iron loss

Let  $X$  be the fraction of the full load kvA at which maximum efficiency occurs.

Cu loss at max<sup>m</sup> efficiency =  $x^2 W_c$

At max<sup>m</sup> efficiency the iron loss is  $W_i$

Iron loss = cu. Loss

$$W_i = \sqrt{\frac{W_i}{W_c}}$$

KvA at max<sup>m</sup> efficiency

$$= \text{F.L KvA} \sqrt{\frac{W_i}{W_c}}$$

$$\eta_{\max}^m = \frac{\frac{o}{p} \text{ at maximum efficiency}}{\frac{o}{p} \text{ at maximum} + W_i + W_c}$$

### **3.13-Open circuit test & S.C test of 1-ph T/F:-**

#### **Open circuit Test:-**

This is also called as no-load test and it is conducted to determine iron loss or core loss of the transformer.

#### **Circuit diagram:-**

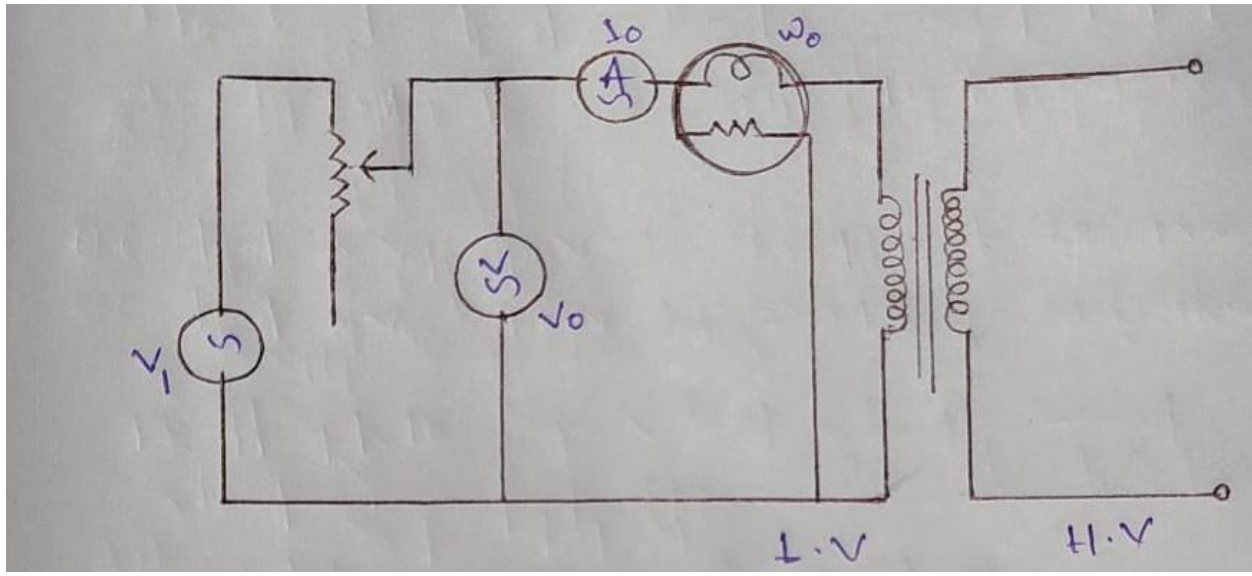

This test is normally conducted on L V side keeping H.V open circuited.

- The measuring instruments like A.C voltmeter ,A C ammeter and wattmeter are connected on the L.V side of the transformer as shown in the above figure.

### Procedure:-

After connecting all necessary measuring instruments on the L.V side, The variance is gradually increased till the voltmeter reads its rated value. Then ammeter and wattmeter readings are noted down. The wattmeter will indicate the iron or core loss.

### Theory:-

From this test, the exciting coil parameters of an equivalent circuit of the transformer are determined as follows.

Let,

$W_0 = W_i$  = Iron loss shown by the wattmeter, w

$V_0$  = No-Load L.V. side rated voltage shown by the voltmeter, v

$I_0$  = No load current shown by the ammeter, A

$\cos \phi_0$  = No load power factor

$$W_i = V_0 I_0 \cos \phi_0$$

$$\Rightarrow \cos \phi_0 = W_0 / V_0 I_0$$

Hence watt full current,  $I_w = I_0 \cos \phi_0$ , A

Similarly

magnetising current,  $I_m = I_0 \sin \phi_0$

So exciting coil resistance,  $R_0 = V_0 / I_w$ , ohm

Exciting coil resistance,  $X_0 = V_0 / I_m$ , ohm

### Short circuit test:-

This is also called as full load test. It is connected to determine full load copper loss of the transformer.

### Circuit Diagram:-

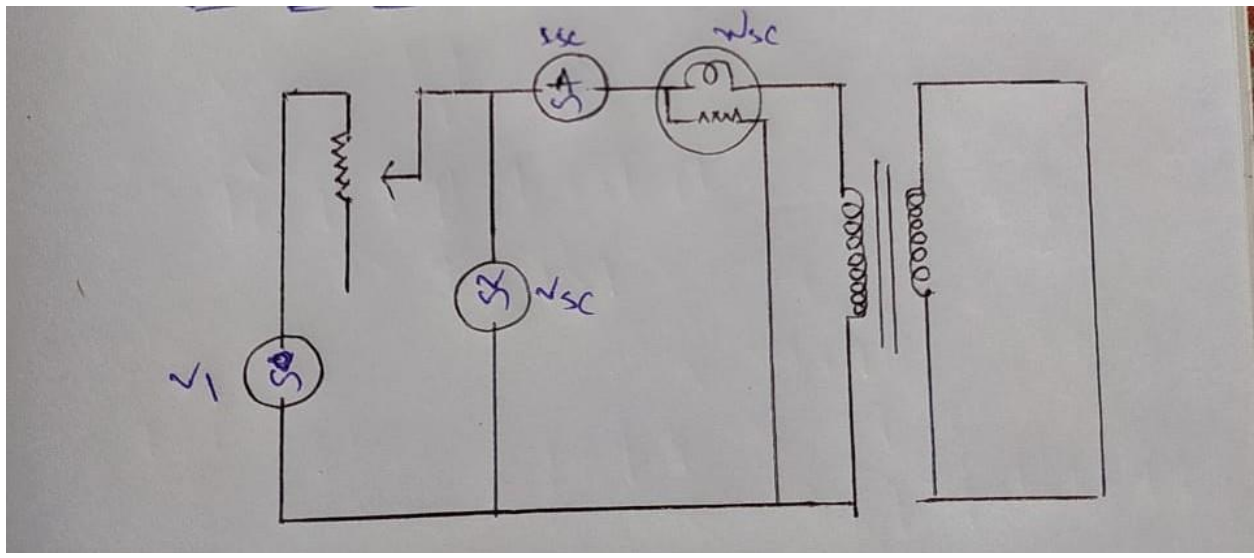

This test is normally conducted on H.V. side keeping L.V. shorted.

- The measuring instruments like A.C voltmeter, ammeter and wattmeter are connected on H.V. side of the transformer as shown in the above figure. Using a thick copper wire, L.V. terminals shorted.

### Procedure:-

After connecting all the measuring instruments, the variance is gradually increased till the ammeter reads it's rated current. It is observed that the rated current is achieved at reduced voltage. Then voltmeter reading, ammeter reading and wattmeter reading are recorded. The wattmeter reading gives full load copper loss.

### Theory:-

From this test , winding parameters can be determined as below.

Let,

$W_{sc}$  = wattmeter reading under short circuit/Full load Cu. Loss, w

$V_{sc}$  = short circuit voltage, v

$I_{sc}$  = short circuit/Full load current shown by the ammeter, A

$R_{01}$  = Equivalent resistance referred to primary side, ohm

$X_{01}$  = Equivalent reactance referred to primary side, ohm

$Z_{01}$  = Equivalent impedance referred to primary side, ohm

If the test is conducted on primary side

$$V_{sc} = I_{sc} Z_{01}$$

$$\Rightarrow Z_{01} = V_{sc} / I_{sc}$$

$$\Rightarrow W_{sc} = I_{sc}^2 R_{01}$$

$$\Rightarrow R_{01} = W_{sc} / I_{sc}^2, \text{ohm}$$

$$\Rightarrow X_{01} = \sqrt{Z_{01}^2 - R_{01}^2}, \text{ohm}$$

### **3.14- Explanation of all day efficiency:-**

#### **Definition:-**

It is defined as ratio of output energy to the input energy.

Mathematically-,

$$\eta_{all} = \text{O/P energy} / \text{I/P energy for 24 hours}$$

#### **Explanation:-**

As we know that a transformer is designed to operate at different loads with different power factors. Some times the transformer may be full loaded, half loaded or one fourth loaded etc. and may be operated with unity power factor, Lagging and leading power factor.

Since it is understood that a Transformer operating at different loads and power factors will have copper losses accordingly, so its efficiency in a day is necessary to determine. Hence all day efficiency of a Transformer can give the overall performance.

Q) find the all day efficiency of a 500 kVA distribution transformer whose copper loss and iron loss at full load are 4.5 kW and 3.5 kW respectively. During a day of 24 hours it is loaded as under.

| No. of hours | Loading in kW | power factor |
|--------------|---------------|--------------|
| 6            | 400           | .8           |
| 10           | 300           | .75          |
| 4            | 100           | .8           |
| 4            | 0             | -            |

Sol<sup>n</sup> →  $W_i = 3.5 \text{ kW}$   
 $W_c = 4.5 \text{ kW}$

For 400 kW at .8 P.F for 6 hours.

$$\text{kVA loading} = \frac{\text{kW}}{\text{P.F}} = \frac{400}{.8} = 500 \text{ kVA}$$

∴ copper loss = 4.5 kW  
 iron loss = 3.5 kW

∴ Total output in kW hours →  
 $= \text{kW} \times \text{time in (h)}$

$$= 400 \times 6 = 2400 \text{ kWh}$$

total loss = 4.5 + 3.5 = 8 kW

∴ total loss in kWh →  
 $8 \times 6 = 48 \text{ kWh}$

For 300kW at .75 P.F for 10 hours

$$\text{kVA rating} = \frac{\text{kW}}{\text{P.F}} = \frac{300}{.75} = 400 \text{ kVA}$$

∴ iron loss

$$\text{Output in kWh} = 300 \times 10 = 3000 \text{ kWh}$$

$$\therefore \text{iron loss} = 3.5 \text{ kW}$$

$$\text{iron loss in kWh} = 3.5 \times 10 = 35 \text{ kWh}$$

$$\text{copper loss} = \left( \frac{400}{500} \right)^2 \times 4.5$$

$$= 2.88 \text{ kW}$$

$$\text{copper loss in kW hours} =$$

$$2.88 \times 10 = 28.8 \text{ kWh}$$

∴ total loss for 10 hours →

$$28.8 + 35 = 63.8 \text{ kWh}$$

For 100 kW at .8 power factor for 4 hours

$$\text{kVA rating} = \frac{\text{kW}}{\text{P.F}} = \frac{100}{.8} = 125 \text{ kVA}$$

$$\text{Output in kWh} = 100 \times 4 = 400 \text{ kWh}$$

$$\therefore \text{iron loss} = 3.5 \text{ kW}$$

$$\text{iron loss in kWh} = 3.5 \times 4$$

$$= 14 \text{ kWh}$$

$$\text{copper loss} = \left( \frac{125}{500} \right)^2 \times 4.5$$

$$= .281 \text{ kW}$$

$$\text{copper loss in kWh} = .281 \times 4$$

$$= 1.125 \text{ kWh}$$

∴ total loss = 14 + 1.125

$$= 15.125 \text{ kWh}$$

For 0 kW at 0.8 power factor 4 hours

$$\text{o/p in kWh} = 0 \times 4 = 0$$

$$\text{copper in kWh} = 0$$

$$\text{iron loss} = 3.5$$

$$\text{iron loss in kWh} = 3.5 \times 4 = 14 \text{ kWh}$$

$$\text{total loss} = 14 + 0 = 14 \text{ kWh}$$

$$\text{total power in kWh in 24 hours}$$

$$= 2400 + 3000 + 400 + 0$$

$$= 5800 \text{ kWh}$$

$$\text{total loss in kWh}$$

$$= 48 + 63.8 + 15.125 + 14$$

$$= 140.925 \text{ kWh}$$

All day efficiency,

$$\eta_{\text{all day}} = \frac{\text{o/p in kWh}}{\text{o/p in kWh} + \text{Losses}} \times 100 \quad (\text{in 24 hours})$$

$$= \frac{5800}{5800 + 140.925} \times 100$$

$$= 97.6\% \quad \underline{\text{Ans}}$$

### 3.15 Condition for maximum efficiency of 1-ph T/F and load , corresponding to max eff.

Condition for maximum efficiency :-

$$\eta = \frac{\text{output}}{\text{input}}$$

$$= \frac{\text{o/p}}{\frac{\text{o}}{p} + \text{losses}}$$

$$= \frac{V_2 I_2 \cos \phi_2}{V_2 I_2 \cos \phi_2 + \text{Iron loss} + \text{copper loss}}$$

Let full load iron loss =  $W_i$

Full load copper loss =  $W_c$

$$= \frac{V_2 I_2 \cos \phi_2}{V_2 I_2 \cos \phi_2 + (W_i + W_c)}$$

$$\eta = \frac{V_2 I_2 \cos \phi_2}{V_2 I_2 \cos \phi_2 + W_i + I_2^2 R_{02}}$$

At maximum efficiency

$$\Rightarrow \frac{d(\eta)}{d I_2} = 0$$

$$\Rightarrow \frac{d}{d I_2} \left( \frac{V_2 I_2 \cos \phi_2}{V_2 I_2 \cos \phi_2 + W_i + I_2^2 R_{02}} \right) = 0$$

$$\Rightarrow \frac{(V_2 I_2 \cos \phi_2 + W_i + I_2^2 R_{02}) V_2 \cos \phi_2 - V_2 I_2 \cos \phi_2 (V_2 \cos \phi_2 + 2 I_2 R_{02})}{(V_2 I_2 \cos \phi_2 + W_i + I_2^2 R_{02})^2}$$

$$\Rightarrow (V_2 I_2 \cos \phi_2 + W_i + I_2^2 R_{02}) V_2 \cos \phi_2 - V_2 I_2 \cos \phi_2 (V_2 \cos \phi_2 + 2 I_2 R_{02}) = 0$$

$$\Rightarrow V_2 I_2 \cos \phi_2 + W_i + I_2^2 R_{02} - I_2 (V_2 \cos \phi_2 + 2 I_2 R_{02}) = 0$$

$$\Rightarrow V_2 I_2 \cos \phi_2 + W_i + I_2^2 R_{02} - V_2 I_2 \cos \phi_2 + 2 I_2 R_{02} = 0$$

$$\Rightarrow W_i + I_2^2 R_{02} - 2 I_2 R_{02} = 0$$

$$\Rightarrow W_i = 2 I_2 R_{02} - I_2^2 R_{02}$$

$$\Rightarrow W_i = I_2^2 R_{02}$$

$$\Rightarrow W_i = W_c$$

$\Rightarrow$  Iron loss = copper loss

Hence efficiency will be maximum when

Iron loss = copper loss

At maximum efficiency the load current

$$I_2 = \sqrt{\frac{W_i}{R_{02}}}$$

(6) Problem

A single phase T/F with the ratio of  $440/110V$ .  
Takes no-load current of  $5A$  at  $.2$  power factor lagging. If the secondary supplies the current of  $120A$  at a power factor of  $.8$  (lag) find out the current taken by the primary.

Data Given

Required Data

$1-\phi$  T/F

$I_1 = ?$

$$I_0 = 5A$$

$$\cos \phi_0 = .2 \text{ (lagging)}$$

$$I_2 = 120A$$

$$\cos \phi_2 = .8 \text{ (lagging)}$$

$$V_1 = 440V$$

$$V_2 = 110V$$

Sol<sup>n</sup>  $\rightarrow$  we know

$$K = \frac{V_2}{V_1} = \frac{110}{440} = \frac{1}{4} = 0.25$$

$$I_1' = KI_2$$
$$= 0.25 \times 120$$
$$= 30A$$

$$\cos \phi_0 = 0.2$$

$$\phi_0 = \cos^{-1}(0.2)$$
$$= 78.4^\circ$$

$$\cos \phi_2 = .8$$

$$\phi_2 = \cos^{-1}(.8)$$
$$= 36.8^\circ$$

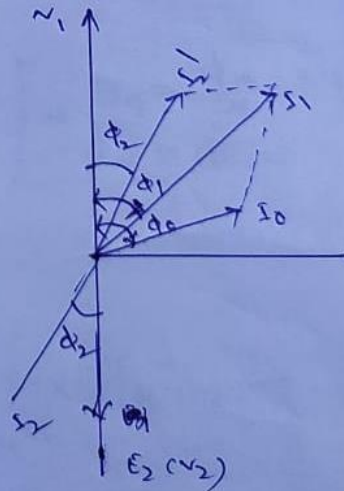

the angle between  $I_0$  and  $I_2'$

$$\theta = \phi_0 - \phi_2$$

$$= 78.4^\circ - 36.8^\circ$$

$$= 41.6^\circ$$

from parallelogram

$$I_1 = \sqrt{I_0^2 + I_2'^2 + 2I_0 I_2' \cos \theta}$$

$$= \sqrt{5^2 + 30^2 + 2 \times 5 \times 30 \cos(41.6^\circ)}$$

$$= 33.9 \text{ A} \quad \text{Ans}$$

(Q) A 30 kVA, 2400/120 V transformer has a high voltage winding of resistance  $.1\Omega$  and leakage reactance of  $.22\Omega$ . The low voltage winding resistance is  $.035\Omega$  and leakage reactance  $.012\Omega$ . Find the equivalent winding resistance reactance and impedance as referred to high voltage side and low voltage side.

Data Given

$$V_1 I_1 = V_2 I_2 = 30 \text{ kVA}$$

$$V_1 = 2400 \text{ V}$$

$$V_2 = 120 \text{ V}$$

$$f = 50 \text{ Hz}$$

$$R_1 = .1\Omega$$

$$X_1 = .22\Omega$$

$$R_2 = .035\Omega$$

$$X_2 = .012\Omega$$

Required Data

$$R_{01} = ?$$

$$R_{02} = ?$$

$$X_{01} = ?$$

$$X_{02} = ?$$

$$Z_{01} = ?$$

$$Z_{02} = ?$$

Sol<sup>n</sup> → In this problem the high voltage side is the primary and low voltage side is secondary winding.

The voltage transformation,

$$K = \frac{V_2}{V_1} = \frac{120}{2400} = .05$$

(i) The equivalent resistance referred to primary side,

$$R_{01} = R_1 + R_2'$$

$$= R_1 + \frac{R_2}{k^2}$$

$$\Rightarrow .1 + \frac{.035}{(.05)^2} = 14.1 \Omega$$

Equivalent Reactance referred to primary side,

$$X_{01} = X_1 + X_2'$$

$$= X_1 + \frac{X_2}{k^2}$$

$$\Rightarrow .22 + \frac{.012}{(.05)^2} = 5.02 \Omega$$

Equivalent impedance as referred to primary side,

$$Z_{01} = \sqrt{(R_{01})^2 + (X_{01})^2} = \sqrt{(14.1)^2 + (5.02)^2}$$

$$= \sqrt{198.81 + 25.2004}$$

$$= 14.96 \Omega$$

(ii) Equivalent resistance referred to secondary side,

$$R_{02} = R_2 + R_1' \Rightarrow R_2 + k^2 R_1 \Rightarrow .035 + .05^2 \times .1$$

$$= 0.03525 \Omega$$

Equivalent Reactance referred to secondary side,

$$X_{02} = X_2 + X_1' \Rightarrow X_2 + k^2 X_1 \Rightarrow .012 + .05^2 \times .22$$

$$= 0.01255 \Omega$$

Equivalent impedance referred to secondary side,

$$Z_{02} = \sqrt{R_{02}^2 + X_{02}^2} = \sqrt{(0.03525)^2 + (0.01255)^2}$$

$$= 0.037 \Omega$$

(3) 10 kVA 200/400 V 50 Hz, 1- $\phi$  transformer gave the following Test results.

OC Test - 200V, 1.3A, 120W on (LV side)

SC Test - 20V, 30A, 200W on (HV side)

Determine the values of exciting coil parameters and winding parameters draw the equivalent circuit as referred to primary/secondary.

Data given

$$P = 10 \text{ kVA}$$

$$V_1 = E_1 = 200$$

$$V_2 = E_2 = 400$$

$$f = 50 \text{ Hz}$$

Required Data

$$R_0 = ?$$

$$X_0 = ?$$

$$R_{01} = ?$$

$$X_{01} = ?$$

OC Test Data

$$V_0 = 200 \text{ V}$$

$$I_0 = 1.3 \text{ A}$$

$$W_0 = 120 \text{ W}$$

SC Test Data

$$V_{sc} = 20 \text{ V}$$

$$I_{sc} = 30 \text{ A}$$

$$W_{sc} = 200 \text{ W}$$

sol<sup>n</sup>  $\rightarrow$  from OC Test Data

watt meter Reading,  $W_0 = V_0 I_0 \cos \phi_0$

$$\Rightarrow \cos \phi_0 = \frac{W_0}{V_0 I_0}$$

$$= \frac{120}{200 \times 1.3}$$

$$= 0.46$$

$$\sin \phi_0 = \sqrt{1 - \cos^2 \phi_0} = \sqrt{1 - 0.46^2}$$

$$= 0.88$$

Wattmeter current,

$$I_w = I_0 \cos \phi_0$$

$$= 1.3 \times 0.46 \text{ A}$$

$$= 0.60$$

Magnetizing current,

$$I_{M1} = I_0 \sin \phi_0$$

$$= 1.3 \times 0.88$$

$$= 1.15 \text{ A}$$

Exciting coil Resistance,

$$R_0 = \frac{V_0}{I_w} = \frac{200}{0.60}$$

$$= 334 \Omega$$

Exciting coil Reactance,

$$X_0 = \frac{V_0}{I_{M1}} = \frac{200}{1.15} = 174 \Omega$$

from SC Test:

Wattmeter Reading,

$$W_{sc} = I_{sc}^2 R_{02}$$

$$\Rightarrow R_{02} = \frac{W_{sc}}{I_{sc}^2} = \frac{200}{30^2}$$

$$= 0.222 \Omega$$

Short circuit voltage,

$$V_{sc} = I_{sc} Z_{02}$$

$$\Rightarrow Z_{02} = \frac{V_{sc}}{I_{sc}}$$

$$\Rightarrow \frac{222}{30} = 0.733 \quad \text{--- (7)}$$

Hence Reactance,  $X_{02}$

$$X_{02} = \sqrt{(Z_{02})^2 - (R_{02})^2}$$

$$= \sqrt{(0.733)^2 - (0.222)^2}$$

$$= 0.698 \Omega$$

Equivalent circuit diagram referred to secondary side is shown below.

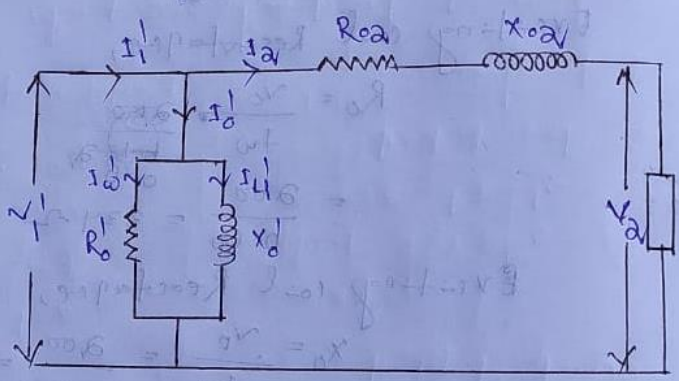

$$R_0' = k^2 R_0$$

$$X_0' = k^2 X_0$$

$$V_1' = k V_1$$

$$I_1' = \frac{I_1}{k}$$

$$I_0' = \frac{I_0}{k}$$

$$k = \frac{V_2}{V_1}$$

Q(2) In a 50 kVA transformer the iron loss = 500 watt and full load copper loss 800. Find efficiency at full load and  $\frac{1}{2}$  full load at .8 p.f lagging.

Given Data

$$V_1 I_1 = V_2 I_2 = 50 \text{ kVA} \\ = 50 \times 10^3$$

$$W_i = 500 \text{ watt}$$

$$W_c = 800$$

$$\cos \phi_2 = .8 \text{ lag}$$

Required Data

$$\eta_{F.L} = ?$$

$$\eta_{\frac{1}{2}F.L} = ?$$

Sol<sup>n</sup> → Case - I

$$\text{output at full load,} = \cancel{50 \times 10^3} \times \text{P.F.} \\ V_2 I_2 \cos \phi_2 = 50 \times 10^3 \times .8 \\ = 40 \times 10^3 \text{ watt}$$

$$\text{Efficiency at full load} \\ = \frac{\text{output at full load}}{\text{output at full load} + W_i + W_c} \\ = \frac{40 \times 10^3}{40 \times 10^3 + 500 + 800} \times 100 \\ = 96.85\%$$

Case - II

$$\text{output at half full load} \\ = \text{P}_{\frac{1}{2}F.L} = \frac{40 \times 10^3}{2} = 20 \times 10^3 \text{ watt}$$

at half load, copper loss is

~~Copper loss~~  $W_{cFL} \frac{1}{4}$

$$C \cdot I^2 \cdot L \frac{1}{4} = \left(\frac{1}{2} I\right)^2 \times 800$$

$$= 200 \text{ watt}$$

$\eta$  at half full load,

$$= \frac{\% P \frac{1}{2} F \cdot L}{\% P \frac{1}{2} F \cdot L + W_{\frac{1}{2}} + W_{c \frac{1}{2} F \cdot L}}$$

$$= \frac{20 \times 10^3}{20 \times 10^3 + 500 + 200}$$

$$= 96.61\%$$

10 (Q) A 40 kVA transformer has iron loss = 450, copper loss = 850 W. Power factor = 0.8 lag. Find the maximum efficiency.

Data given

$$P = 40 \text{ kVA}$$

$$W_i = 450 \text{ W}$$

$$W_c = 850 \text{ W}$$

$$P.F. = 0.8 (\text{lag})$$

Required data

$$\eta_{\text{max}} = ?$$

Sol<sup>n</sup> → o/p kVA at max<sup>n</sup> efficiency

$$= \text{F.L. kVA} \times \sqrt{\frac{W_i}{W_c \text{ F.L.}}}$$

$$= 40 \times \sqrt{\frac{450}{850}} = 29.10 \text{ kVA}$$

o/p in watt at max<sup>n</sup> efficiency

$$= 29.10 \times 10^3 \times 0.8$$

$$= 23280 \text{ watt}$$

$$\eta_{\text{max}} = \frac{\text{o/p max eff}}{\text{o/p max} + W_i + W_c}$$

$$= \frac{23280}{23280 + 450 + 850}$$

$$= \frac{23280}{24580}$$

$$= 94.71\%$$

$$= 96.27\%$$

(i) The readings of the instrument on No load test & short circuit test of a 10 kVA  $450/120$  V 50 Hz transformer are.

OC Test  $\rightarrow V_0 = 120$  V,  $I_0 = 4.2$  A,  $W_0 = 80$  W (Lvs. side)

SC Test  $\rightarrow V_{sc} = 9.65$  V,  $I_{sc} = 22.2$  A,  $W_{sc} = 120$  W (Hvs. side)

Find out the equivalent ~~short~~ circuit constant ~~short~~ <sup>or</sup> parameters.

(ii) Efficiency and voltage regulation for an 80% lagging P.F load.

(iii) The efficiency at half full load and 80% lagging power factor.

Data Given

$$V_1 I_1 = V_2 I_2 = 10 \text{ kVA}$$

$$E_1 = 450, E_2 = 120$$

from OC Test

$$V_0 = 120 \text{ V,}$$

$$I_0 = 4.2 \text{ A}$$

$$W_0 = 80 \text{ W}$$

from SC Test

$$V_{sc} = 9.65 \text{ V}$$

$$I_{sc} = 22.2 \text{ A}$$

$$W_{sc} = 120 \text{ W}$$

Required Data

(i) ckt parameters

(ii)  $\eta = ?$  and %R? at 80% (lag) P.F

(iii)  $\eta_{1/2 F.L} = ?$  at 80% lag P.F

From OC Test data:-

$$W_0 = V_0 I_0 \cos \phi_0$$

$$80 = 120 \times 4.2 \times \cos \phi_0$$

$$\cos \phi_0 = \frac{80}{120 \times 4.2} = 0.157$$

$$\sin \phi_0 = \sqrt{1 - \cos^2 \phi_0} = 0.986$$

$$\therefore I_w = I_0 \cos \phi_0 = 4.2 \times 0.157 = 0.66 \text{ A}$$

$$I_y = I_0 \sin \phi_0 = 4.2 \times 0.986 = 4.14 \text{ A}$$

$$R_0 = \frac{V_0}{I_w} = \frac{120}{0.66} = 181.8 \Omega$$

$$X_0 = \frac{V_0}{I_y} = \frac{120}{4.14} = 29.0 \Omega$$

From SC Test:-

$$W_{sc} = I_{sc} Z_{sc} \Rightarrow Z_{sc} = \frac{W_{sc}}{I_{sc}} = \frac{9.65}{22.2} = 0.434 \Omega$$

$$W_{sc} = 120$$

$$\Rightarrow I_{sc}^2 R_{01} = 120$$

$$\Rightarrow R_{01} = \frac{120}{I_{sc}^2} = \frac{120}{22.2^2} = 0.243 \Omega$$

$$\therefore X_{01} = \sqrt{Z_{01}^2 - R_{01}^2} = \sqrt{(0.434)^2 - (0.243)^2} = 0.354$$

Hence equivalent circuit diagram as referred to primary.

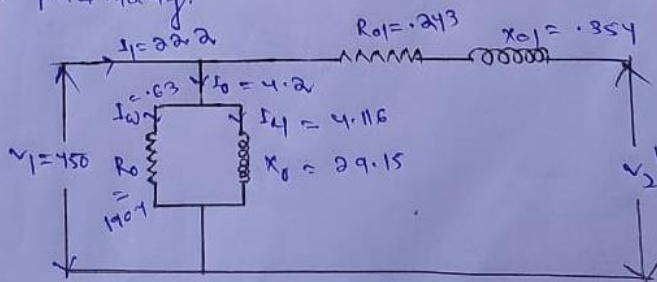

$$I_1 = \frac{10 \times 10^3}{450} = 22.2$$

$$P.F. = 80\%$$

$$= \frac{80}{100} = 0.8$$

$$\cos \phi = 0.8$$

$$\sin \phi = 0.6$$

The approximate voltage drop as referred to primary is  $I_1 R_{01} \cos \phi + I_1 X_{01} \sin \phi$

$$= 22.2 \times 0.243 \times 0.8 + 22.2 \times 0.354 \times 0.6$$

$$= 9.03 \text{ V}$$

$\therefore$  Voltage Regulation,

$$\% R = \frac{\text{drop}}{450} \times 100$$

$$= \frac{9.03}{450} \times 100$$

$$= 2.006\%$$

$$= 2\%$$

$$\eta = \frac{o/p}{i/p} \times 100$$

The full load o/p =  $V_2 I_2 \cos \phi$

$$= 10 \times 10^3 \times 0.8 = 8000 \text{ W}$$

total loss = iron loss + copper loss

$$= 80 + 120 = 200 \text{ W}$$

i/p the transformer =  $8000 + 200$

$$= 8200 \text{ watt}$$

$$\eta = \frac{o/p}{i/p} \times 100 = \frac{8000}{8200} \times 100$$

$$= 97.5\%$$

For half load  
 The iron loss remain constant  
 i.e.  $w_i = 80 \text{ watt}$   
 But the copper at half load,  
 $= \frac{1}{2^2} \times \text{copper loss at full load}$   
 $= \frac{1}{4} \times 120 = 30 \text{ watt}$   
 $\therefore$  total loss at half load,  
 $= \text{iron loss} + \text{copper loss}$   
 $= 80 + 30 = 110$   
 input at half load,  
 $= \text{output at half load} + \text{loss}$   
 $= \frac{8000}{2} + 110$   
 $= 4110 \text{ watt}$   
 $\eta_{\text{half load}} = \frac{\text{o/p at half load}}{\text{i/p at half load} \times 100}$   
 $= \frac{4000}{4110} \times 100$   
 $= 97.3\%$

### 3.16-parallel operation of single phase transformer:-

#### Definition:-

It is defined as a process by which electrical loads are equally shared among the transformer.

#### Explanation:-

As we know that a transformer is designed to deliver rated load. If load on this transformer exceeds from its rated value then it is said to be over loaded. During this period, due to heavy current through the winding, windings may be damaged. At the same time this transformer can not meet demand of the consumers. Hence to meet extra load of consumers, another Transformer must be connected in parallel with this transformer.

While operating two transformer in parallel following condition must be satisfied.

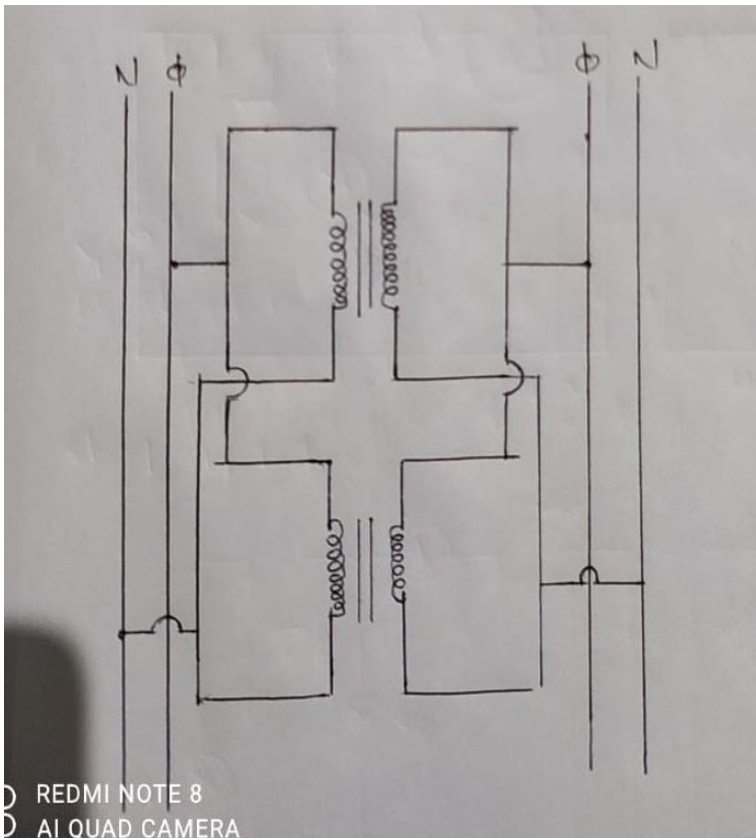

REDMI NOTE 8  
AI QUAD CAMERA

1. Polarity of primary and secondary winding must be properly matched .
2. Primary windings are properly connected with the supply mains.
3. Supply frequency should be equal to that of frequency of the Transformer.
4. transformation ratio in both the Transformers should be same.
5. Impedance of windings should be equal in both the Transformers.

## Questions :-

### Short questions with answers:-

(1) Does a transformer work on DC? If not why .

Ans:-No because in a DC machine flux produced in the primary winding remains constant, Accordingly Faraday's laws of electromagnetic induction, no emf can be induced in secondary side ( $e = d\phi/dt = d(\text{constant})/dt = 0$ )

Hence a Transformer can not work on DC.

(2) which loss is constant irrespective of loads?

Ans-Irrespective of loads iron or core loss remains constant.

(3) why Transformer is rated in KVA?

Ans:- Generally the transformer is rated in volt ampere because the rating of Transformer depends open the heating of the transformer i.e depends open the losses. The iron loss depends open the voltage and copper loss depends open the current so the total loss depends open voltage and current i.e depend open the VA and not depend open the power factor of the load so Transformer is rated in VA.

(4) If full load copper loss in a transformer is 400w, what is the loss for the half load ?

Ans:-At half load the copper loss will be 100w.

$$X^2 W_{cu} = (1/2)^2 \times 400 = 100w$$

(5) At what condition efficiency of a Transformer is maximum?

Ans:-The efficiency of a Transformer will be maximum only when copper loss at any load is equal to the iron loss.

(6) Why the efficiency of a Transformer is higher than that of other electrical machines?

Ans:-The efficiency of a Transformer is more than that of other electric machines because the transformer has comparatively less losses due to absent of mechanical loss.

(7) what is voltage regulation ?

Ans- It is defined as the ratio of drop and the full load voltage.

- It is calculated in percentage.

$\%R = (\text{Drop in voltage} / \text{full load voltage}) \times 100.$

(8) Which loss gives core loss of the transformer?

Ans:- Generally O.C test gives core loss of a Transformer.

(9) Using which test, we can find out the full load Cu. Loss.

Ans:- Using S.C test, we can calculate the full load Cu. Loss.

### **Long questions:-**

- (1) Explain various parts and working of single -phase Transformer.
- (2) Derive at what condition the efficiency of a Transformer is maximum.
- (3) Explain with phaser diagram of an ideal transformer on -load.
- (4) Derive the approximate voltage drop of a single -phase Transformer.
- (5) Draw the equivalent circuit diagram of a single-phase Transformer with all the parameters.
- (6) What are the different methods for cooling the Transformer?
- (7) Explain with circuit diagram the open circuit and short circuit test of the transformer?
- (8) Explain parallel operation of the single-phase Transformer.
- (9) Problems on (losses, eff, equivalent ckt, voltage regulation, on load test).

# CHAPTER NO-04

## Auto Transformer

4.1. Definition: It is defined as a transformer in which a single winding can act both for primary as well as secondary windings.

**Principle:** It works under the principle of conduction as well as induction principle.

**Construction:** An Auto Transformer consists of laminated core and windings. A large number of turns are wound over the core and called as windings. From this single winding, tapping is done to Secondary windings. In this transformer we can save copper as compared to the two winding transformers.

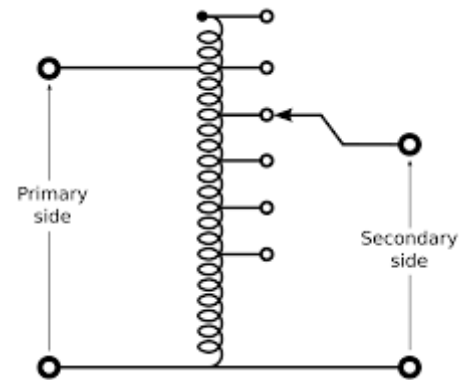

4.2. Working: When a.c. supply is given to the primary windings, as like 1- phase T/F ,an alternating flux starts to flow through the core and hence the windings also . So this flux links with the secondary turns by which certain emf will be induced. This secondary induced emf depends on the tapping.

4.3. Saving of Copper in an Auto Transformer:

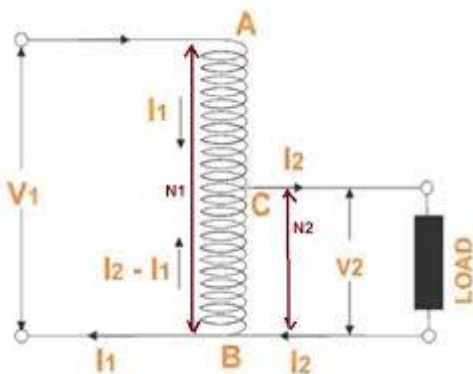

Let

$N_1$  = Primary number of turns

$N_2$  = Secondary number of turns

$I_1$  = Primary current, A

$I_2$  = Secondary Current, A

$V_1$  = Primary voltage, V

$V_2$  = Secondary Voltage, V

K = Transformation ratio

$W_0$  = Weight of Copper in an Ordinary or two winding transformer, Kg

$W_a$  = Weight of Copper in an Auto transformer, Kg

We know that,  $MMF \propto NI$

But  $N \propto L$  and  $I \propto A$

Hence  $NI \propto LA$

$\propto$  Volume

$\propto$  Weight of Copper

So  $MMF \propto$  Weight of the copper  $\propto NI$

Now,  $W_0 \propto$  weight of copper in (primary + secondary) windings

$\propto (N_1 l_1 + N_2 l_2)$

Similarly  $W_a \propto MMF_{AC} + MMF_{CB}$

$\propto (N_1 - N_2) l_1 + N_2 (l_2 - l_1)$

$\propto N_1 l_1 - N_2 l_1 + N_2 l_2 - N_2 l_1$

$\propto N_1 l_1 + N_2 l_2 - 2 N_2 l_1$

Now

$$\begin{aligned} \frac{W_a}{W_0} &= \frac{N_1 I_1 + N_2 I_2 - 2 N_2 I_1}{N_1 I_1 + N_2 I_2} \\ &= \frac{N_1 I_1 + N_2 I_2}{N_1 I_1 + N_2 I_2} - \frac{2 N_2 I_1}{N_1 I_1 + N_2 I_2} \\ &= 1 - \frac{2 N_2 I_1}{N_1 I_1 + N_2 I_2} \end{aligned}$$

In an ideal transformer, primary MMF = Secondary MMF

i.e.  $N_1 l_1 = N_2 l_2$

Hence, 
$$\begin{aligned} \frac{W_a}{W_0} &= 1 - \frac{2 N_2 I_1}{N_1 I_1 + N_2 I_2} \\ &= 1 - \frac{I_1}{I_2} \end{aligned}$$

$$W_a = (1-K) W_0 \quad \text{Kg where } K < 1$$

Saving of copper =  $W_0 - W_a$

$$= W_0 - W_0 + K W_0$$

$$= K W_0$$

$$\text{Saving of Copper} = K W_0 \quad \text{Kg}$$

Power Transfer Formula:

1. Power transferred Inductively =  $P_1 (1-K)$

2. Power Transferred Conductively =  $K P_1$

#### **4.4. Applications of Auto Transformer:**

An auto transformer is used

i) In Electric locomotives to control equipments

ii) In Transmission lines as 1:1 transformer

iii) As starter in 3-phase induction motor

iv) As furnace transformer

Q1. An Auto transformer supplies a load of 3Kw at 115V at a unity power factor. If the applied primary voltage is 230V, find the power transferred to the load a) Inductively b) Conductively.

**Given Data:**

$$P_o=3KW$$

$$V_2=115V$$

$$\cos\phi=1$$

$$V_1=230V$$

**Solution:**

$$\text{Transformation ratio } K = \frac{V_2}{V_1} = \frac{115}{230} = 0.5$$

$$\text{Here } P_i = P_o = 3KW$$

$$\begin{aligned} \text{a) Power transferred Inductively} &= P_i (1-K) \\ &= 3(1-0.5) = 1.5KW \quad (\text{Ans}) \end{aligned}$$

$$\begin{aligned} \text{b) Power Transferred Conductively} &= K P_i \\ &= 0.5 \times 3 = 1.5 KW \quad (\text{Ans}) \end{aligned}$$

**Required Data**

a) Power inductively

b) Power Conductively

#### 4.5:: **TAP CHANGING TRANSFORMER**

Definition: It is defined as a transformer in which, voltage is obtained or affected by changing the number of turns provided in the tapings. Generally taps are provided or used in the hv side. Of the transformer.

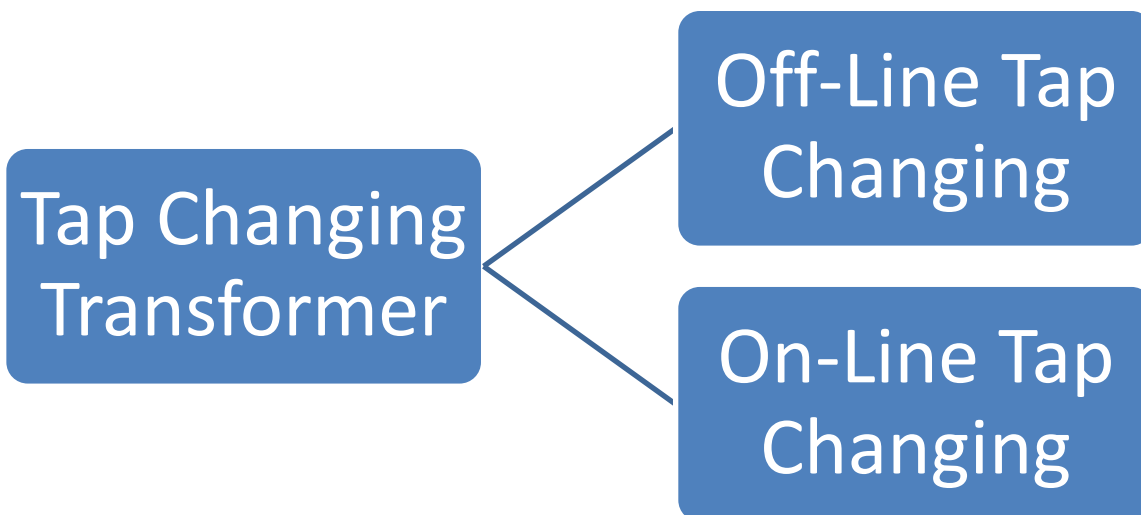

##### 4.5.1: Off-Line Tap Changing Transformer:

This is one of the very cheapest & useful method. In this method, the tap changing is done by disconnecting the load from the transformer. The simple off load tap changer transformer is shown in the fig 3.68 below. It has 8 studs marked 1 to 8. The winding is also tapped at eight points & connected with these studs. The movable contact arm (A) may be rotated by means of hand wheel mounted externally on the transformer tank. So according to the tapping position, we can get the output voltage.

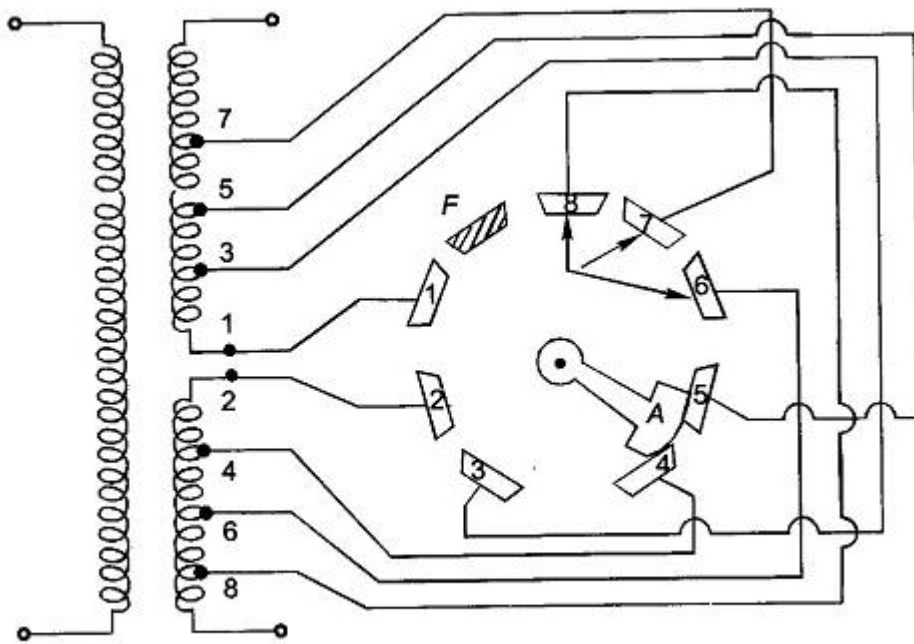

**Fig. 3.68** No-load tap changer

#### 4.5.2: On-Line Tap Changing Transformer:

This is one of the useful method .In this method, the tap changing is done by holding the load on the transformer.

An on-line tap changing Transformer (OLTC) consists of an open load tap changer. It is also known as On- Circuit Tap Changer (OCTC).In this transformer, the turns ration can be changed without breaking the circuit. Generally it consists of 33 taps. 1 tap is centre rated tap , another 16 taps meant for increasing the ration of windings and remaining 16 taps are meant for decreasing the ration of windings. The OLTC may of Resistor type or Reactor type to limit the short circuit current. But in modern design, the current limiting is almost carried out by a pair of resistors.

Basically this transformer is used where there is frequent interruption of power supply. Now days in all power transformers this OLTC is used.

## Chapter No -05

### INSTRUMENT TRANSFORMER

**5.1. Definition:** It is defined as a transformer which is used to measure electrical quantities like Current, Voltage, Power, Frequency and Power factor etc. These transformers are used in Relays to protect the power system.

#### 5.2. Types of Instrument Transformer:

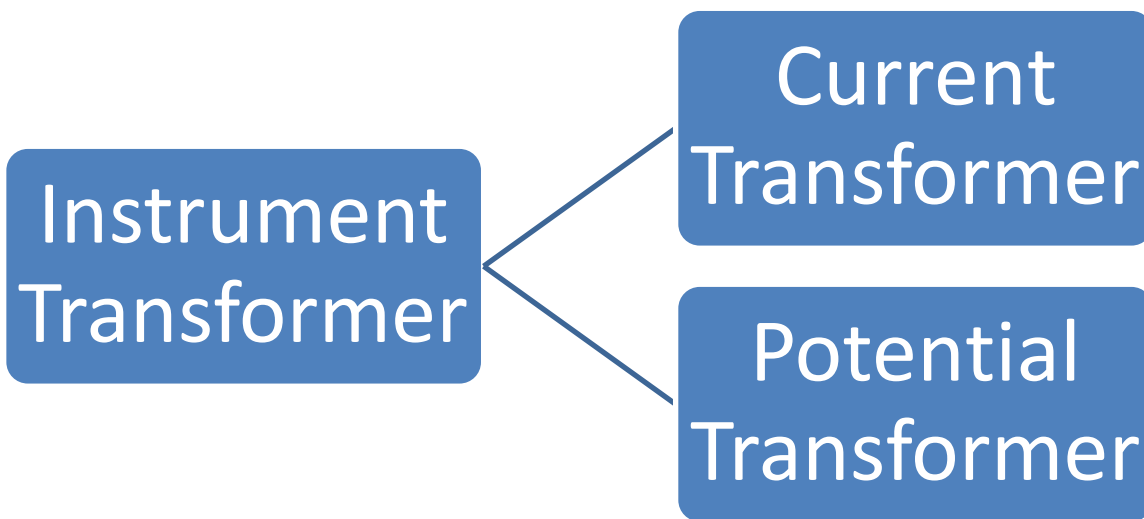

##### 5.2.1. Current Transformer (CT):

**Definition:** It is defined as an instrument transformer which measures electric current.

**Explanation:** This type of transformer has two windings like Primary and secondary winding. The primary winding consists of **few numbers of turns** and connected to the supply main in series. Sometimes it is also called as series transformer. Similarly the secondary winding has comparatively more no of turns and connected with an ammeter having low resistance. Hence we say the secondary winding works with full short circuit condition. The turns ration from primary to secondary is 100:5. one terminal of the secondary winding is also grounded to avoid huge leakage current. Before disconnecting the ammeter, the secondary winding is to be disconnected by putting on the switch as shown in the fig bellow.

This type of transformer is used in power systems to step down the voltage from high level to a low level with the help of 5A ammeter. Since the current in secondary is proportional to the current in primary, so while connecting with supply main for measurement of current then proportionate current can be recorded from the ammeter.

3 Phase  
AC Supply

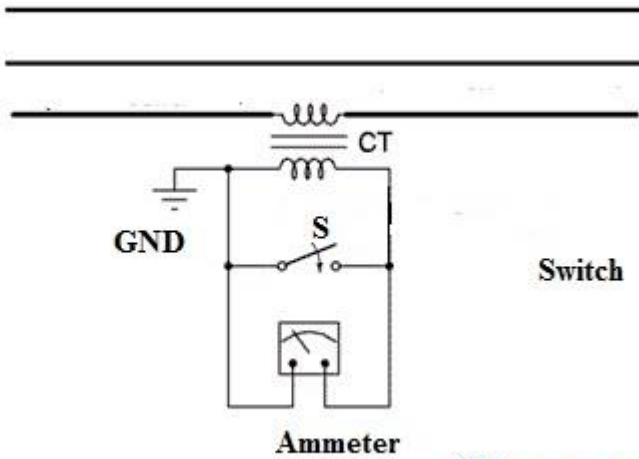

Switch

Ammeter

©Elprocus.com



Digital Clamp Meter

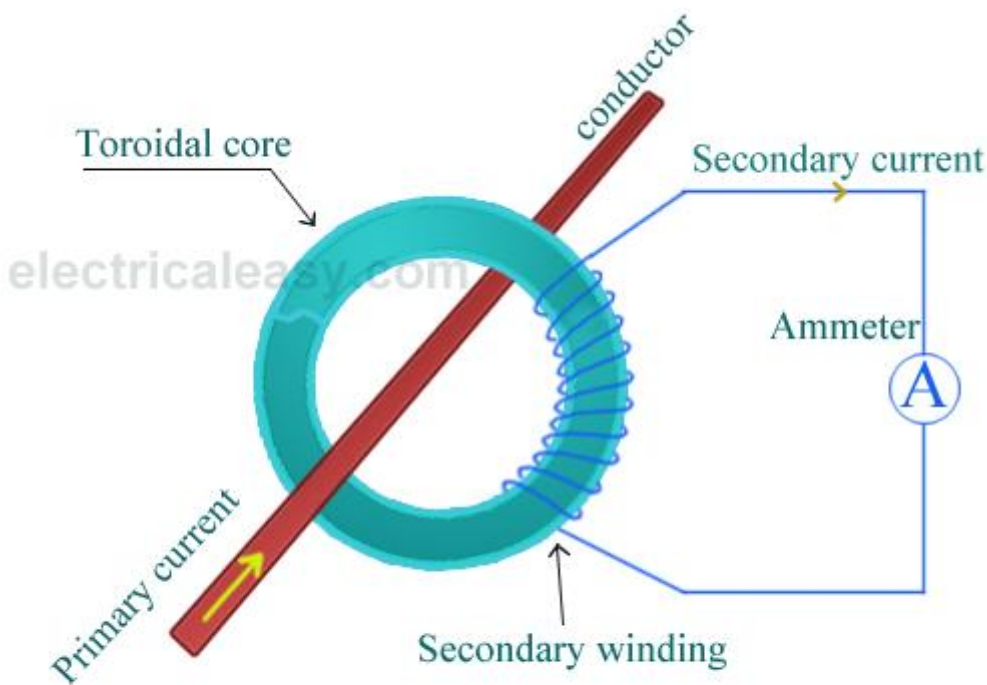

Current Transformer

## 5.2.2 Potential Transformer:

**Definition:** It is defined as an instrument transformer which measures electric potential.

**Explanation:** This type of transformer has two windings like Primary and secondary winding. The primary winding consists of comparatively more no of turns and connected to the supply main in parallel. Sometimes it is also called as parallel transformer. Similarly the secondary winding has few no. of turns and connected with a voltmeter having high resistance. Hence we say the secondary winding works with open circuit condition. The turns ration from primary to secondary is 600:120. one terminal of the secondary winding is also grounded to protect an operator from high voltage hazard.

This type of transformer is used in power systems to step down the voltage from high level to a low level with the help of small rating voltmeter ranging from 110 V to 120 V. The diagram of a potential transformer is shown bellow. Since the current in secondary is proportional to the current in primary, so while connecting with supply main for measurement of current then proportionate current can be recorded from the ammeter.

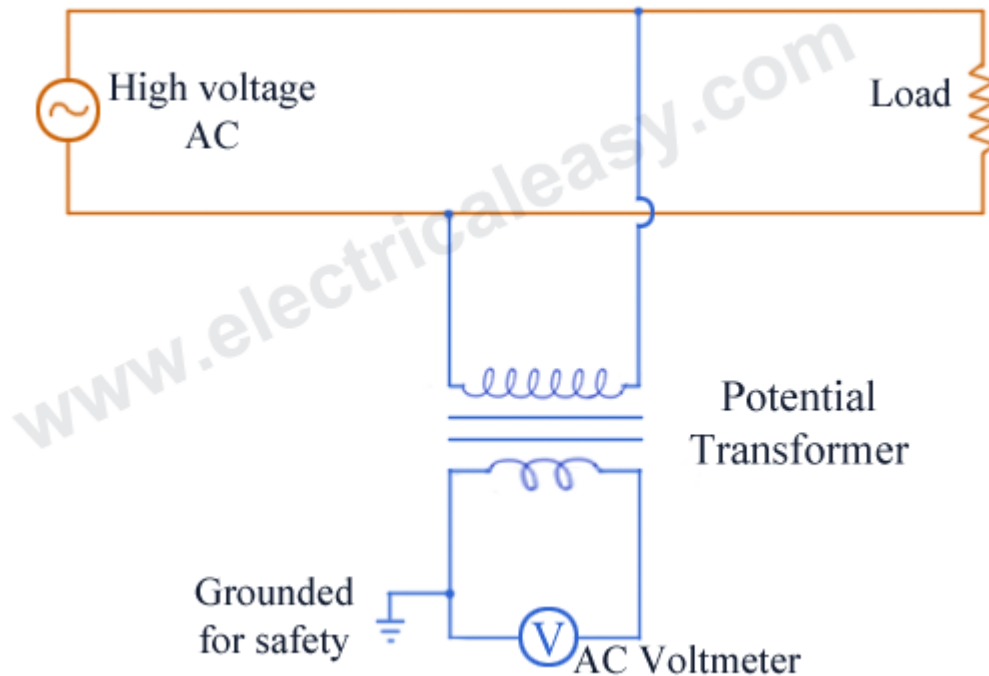

3-Phase  
AC System

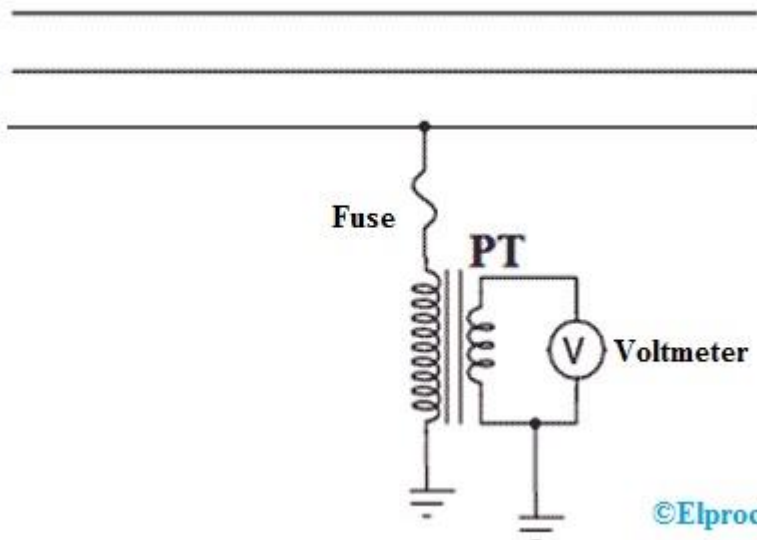

# Difference between Current Transformer and Potential Transformer

The difference between the current transformer & potential transformer is discussed below.

| Current Transformer (CT)  | Potential Transformer (PT)   |
|---|--|
| The connection of this transformer can be done in series with the power circuit                                   | The connection of this transformer can be done in parallel with the power circuit                  |
| The secondary winding is connected to an ammeter  | The secondary winding is connected to a voltmeter  |
| The design of this can be done by using the lamination of <u>silicon</u> steel.                                   | The designing of this can be done by using high-quality steel which operates at low-flux densities |
| The primary winding of this transformer carries the current.  | The primary winding of this transformer carries the voltage  |
| It includes less number of turns  | It includes a large number of turns  |
| The secondary winding of this transformer works in the condition of a short circuit.                              | The secondary winding of this transformer works in the condition of an open circuit.               |
| The primary current mainly depends on the flow of current within the power circuit                                | The primary current mainly depends on the secondary load.  |
| The insulation breakdown can be avoided by connecting the secondary winding of this transformer to the earth.     | The secondary winding can be connected to the earth to protect the operator from a huge voltage    |
| The range of this transformer is 1A or 5A   | The range of this transformer is 110v  |
| This transformer ratio is high  | This transformer ratio is low  |
| The input of this transformer is the constant current   | The input of this transformer is a constant voltage  |
| This type of transformers is classified into two types like wound type & closed core.                             | This type of transformer is classified into two types like electromagnetic & capacitor voltage     |
| The impedance of this transformer is low  | The impedance of this transformer is high  |
| These transformers are used to measure current, power, monitoring the operation of power grid & protective relay. | These transformers are used to measure, operating protective relay & power source.                 |

## AUTO TRANSFORMER:

### **Very short Type Questions with Answers:**

Q1: Write important advantages of an auto transformer over the ordinary transformer

Ans: An auto transformer has a great advantage that it consists of only a single winding from where we can also get secondary winding. Another advantage is that we can save copper for the same rating of ordinary transformer.

Q2. What is use of an auto transformer?

[S-14, S-15, S-19

Ans: An auto transformer is used

- i) In Electric locomotives to control equipments
- ii) In Transmission lines as 1:1 transformer
- iii) As starter in 3-phase induction motor
- iv) As furnace transformer

### **Long Questions:**

Q1.What is an auto transformer, explain with a neat diagram?

Q2.How can you save the copper in an auto transformer over the two winding transformer, derive it?

Q3.Explain in brief, the On-Line Tap changing Transformer?

Q4. Explain in brief, the Off-Line Tap changing Transformer?

## INSTRUMENT TRANSFORMER

### **Very short Type Questions with Answers:**

Q1. What is instrument transformer? What are their types?

Ans: It is defined as a transformer which is used to measure electrical quantities like Current, Voltage, Power, Frequency and Power factor etc. These transformers are used in Relays to protect the power system.

It is of two types such as Current Transformer (CT) & Potential Transformer (PT).

Q2.What is the physical concept of primary winding of a CT?

Ans: The primary winding of a CT consists of few numbers of turns & is connected in series with the supply main.

### **Long Questions:**

Q1.Explain the construction and working of a CT?

Q2. Explain the construction and working of a PT?